



Recorder



Flow



Pressure



Temp



Analyzer



Level

Datasheet

Membrane Dissolved Oxygen

Electrode

SUP-DO-7011

Supmea[®]

Committed to process automation solutions

E-mail: info@supmea.com

www.supmea.com

Datasheet**Membrane Dissolved Oxygen Electrode
SUP-DO-7011**

Dissolved oxygen sensors have high stability and reliability. Continuous measurement of dissolved oxygen in fields such as urban sewage treatment, industrial wastewater treatment, aquaculture, and environmental monitoring.

Applications

- urban sewage treatment
- industrial wastewater treatment
- Aquaculture
- environmental monitoring

Features

- high precision
- rapid response
- High anti-interference capability
- Temperature, pressure and salinity compensation
- Easy maintenance and long life

**Product name**

Principle

The membrane-covered dissolved oxygen (DO) electrode works by allowing oxygen to diffuse through a permeable membrane to the cathode, where it reacts to generate a current. This current is measured and converted to a dissolved oxygen concentration reading. Regular calibration and temperature compensation ensure accuracy.

Parameters	
Measurement Range/Pressure	0-20mg/L 0.6MPa
Electrode Shell Material	PVC or 316L
Cable Length	5m (Double shielding)
Membrane Head Material	Steel sand mesh metal film
Breathable Thickness	100um
Temperature Compensation Resistor/Temperature	Pt100、Pt1000、2.252K etc (0-60℃)
Upper Measurement Limit	20mg/L
Lower Measurement Limit	0.01mg/L (20℃)
Measurement Error	±<0.01mg/L
Polarization Time	60min
Polarization Voltage	0.7V
Air Current/Maximum Current	50-80nA/0.1mg/L MAX: 3.5uA
Response Time	2min (90%, 20℃)
Minimum Flow Rate	2.5cm/s
Zero Oxygen	<0.01mg/L
Drift	<2%/month
Calibration Interval Time	>60 days
Sensor Lifespan	>2 years

Wiring

Number		Color	Instrument Connection Point
1	TEMP	White	Connect instrument temperature compensation A
2	TEMP	Black	Connect to instrument temperature compensation B
3	DO-	Yellow	Connect to the instrument DO-
4	DO+	Transparent Core Wire	Connect to the instrument DO+
5	GND	Blue Wire	Connect to DGND instrument

Dimension

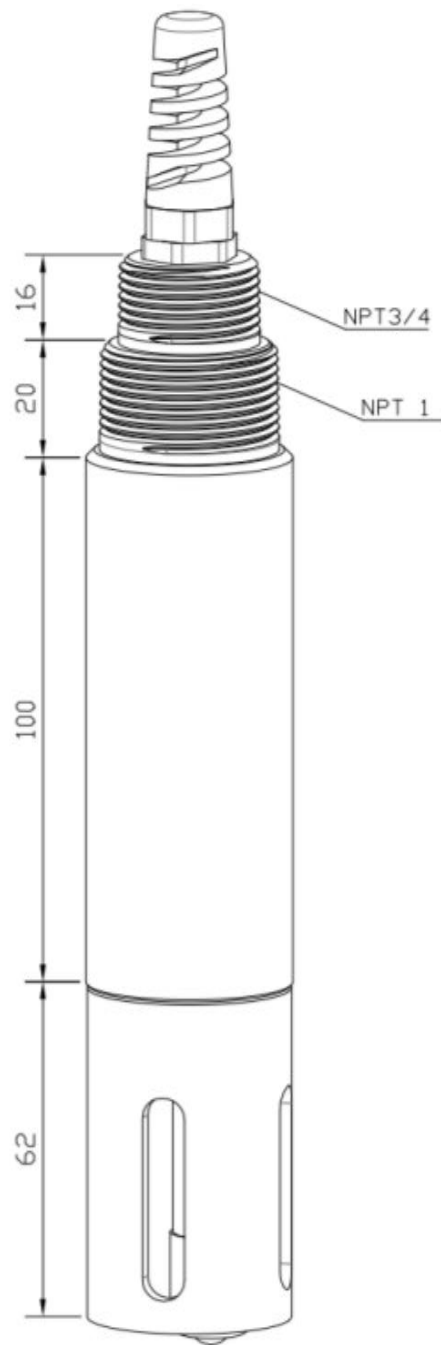

Installation

■ Installation

- 1、 Place the electrode in a vertical position and unscrew the protective cover of the membrane head.
- 2、 Unscrew the film head.
- 3、 Rinse the inside of the electrode with distilled water and dry it with cotton paper. After using the electrode for a period of time, if black hair is found inside the electrode, use fine sandpaper with a grit of 1000 or more to polish it.
- 4、 After each membrane or electrolyte change, the electrode needs to be repolarized and recalibrated.
- 5、 Electrode polarization: After the electrode is connected to the instrument, it is polarized when it is continuously powered on for more than two hours Calibration can only be performed after polarization.

Ordering code

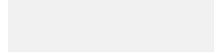

SUP-DO-7011 -1-05-PB			Description
SUP-DO-7011	-	-	
Temperature Compensation Type	1	-	NTC 10K
Cable Length		05	5m
		10	10m
		15	15m
		20	20m
		30	30m
		XX	Others
Housing Material and Thread Type		PB	304SS/PVC, NPT3/4 Thread