



Recorder



Flow



Pressure



Temp



Analyzer



Level

Datasheet

Wall-Mounted Ultrasonic

Flow Meter

SUP-1158S

Supmea

Committed to process automation solutions

E-mail: info@supmea.com

www.supmea.com

Datasheet**Wall-mounted ultrasonic flow meter
SUP-1158s**

The wall-mounted ultrasonic flow meter is designed to measure the fluid velocity of liquid within a closed conduit. The transducers are a non-contacting, clamp-on type, which will provide benefits of non-fouling operation and easy installation.

The SUP-1158S wall-mounted ultrasonic flow meter can be applied to a wide range of pipe flow measurements. Applicable liquids include pure liquids as well as liquid with small quantity of tiny particles.

Applications

- Petrochemical
- Pharmaceutical
- Paper industry
- Metallurgy
- Electric power
- Environmental protection
- Food and beverage

Features

- Linearity: 0.5%.
- Repeatability: 0.2%.
- Accuracy: $\pm 1\%$.
- Easy to operate.
- Several type transducers for selection, measuring pipe size is from DN15mm to DN6000mm.
- Adopt low voltage, multi-pulse technology to improve accuracy, useful life and reliability.
- Powerful recording function, record the totalizer data of the last 64 days/64 monthes/5 years.

**Wall-mounted Ultrasonic flow meter**

Principle

Ultrasonic flowmeters measure flow based on the Transit-Time Difference Method. This method utilizes two ultrasonic sensors mounted to transmit and receive signals in opposite directions through the fluid medium. By measuring the difference in the propagation time of ultrasonic waves traveling with the flow (downstream) and against the flow (upstream), the fluid velocity is determined indirectly. The volumetric flow rate is then calculated based on this velocity and the pipe's cross-sectional area.

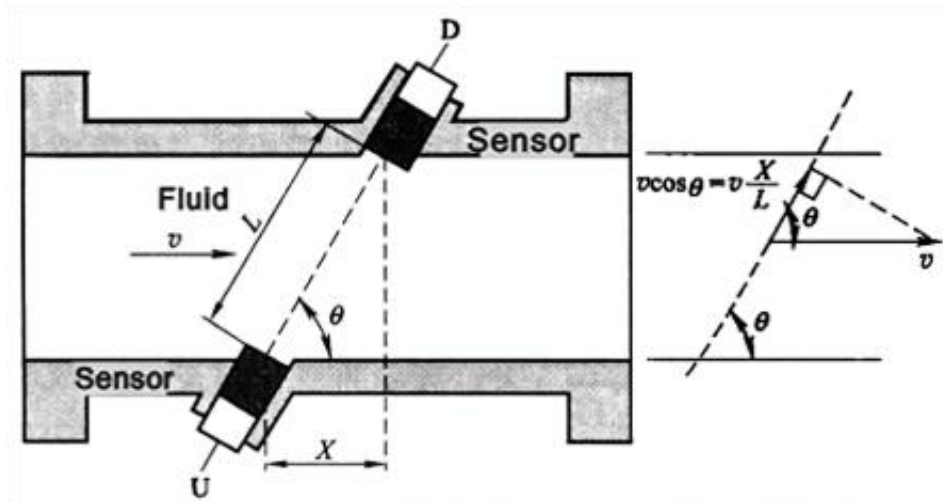

The flow velocity of the fluid between the upstream sensor (U) and the downstream sensor (D) can be calculated using Formula (1) and (2):

$$t_{ud} = \frac{L}{C + V_i \cos \theta}$$

$$t_{du} = \frac{L}{C - V_i \cos \theta}$$

By solving Equations (1) and (2), the average flow velocity and the sound speed C can be derived as:

$$v_i = \frac{L}{2 \cos \theta} \times \frac{t_{du} - t_{ud}}{t_{du} t_{ud}} = \frac{L^2}{2X} \times \frac{t_{du} - t_{ud}}{t_{du} t_{ud}}$$

$$C = \frac{L}{2} \times \frac{t_{du} + t_{ud}}{t_{du} t_{ud}}$$

Where:

t_{du} — Transit time of the ultrasonic pulse from the upstream sensor (U) to the downstream sensor (D);

t_{ud} — Transit time of the ultrasonic pulse from the downstream sensor (D) to the upstream sensor (U);

L — Acoustic path length between the upstream and downstream sensors;

X — Axial distance between the upstream and downstream sensors;

v_i — Average flow velocity of the fluid;

θ — Acoustic propagation angle relative to the flow axis.

Parameters	
Performance parameters	
Measured variables	Flow; cold and heat energy
Nominal diameter	Clamp-on type: DN20~DN1200 Bracket type: DN20~DN700 Insertion type: DN50-DN6000 Inline type: DN15~DN1200
Accuracy	Level 1.0
Output	
Transmitter output	(4~20)mA current output, output accuracy 0.1%FS, load resistance $\leq 1000\Omega$
Communication output	RS485 interface, MODBUS
Frequency/pulse output	Pulse width (0~1000) ms, default 200ms
Relay output	One relay output
Electrical specifications	
Power supply	AC: (85-264)V DC: (8~36)V
Power consumption	1.5W
Electrical interface	PG7
Process conditions	
Medium temperature	Normal temperature type: (-30~90) $^{\circ}\text{C}$ High temperature type: (-30~130) $^{\circ}\text{C}$
Environmental conditions	
Ambient temperature	-20 $^{\circ}\text{C}$ -60 $^{\circ}\text{C}$
Ambient humidity	(0~80%)RH
Protection level	Host: IP65 Sensor: IP65 or IP68

Wiring

(1) Connection Terminals

The terminals of the ultrasonic flowmeter is shown as below:

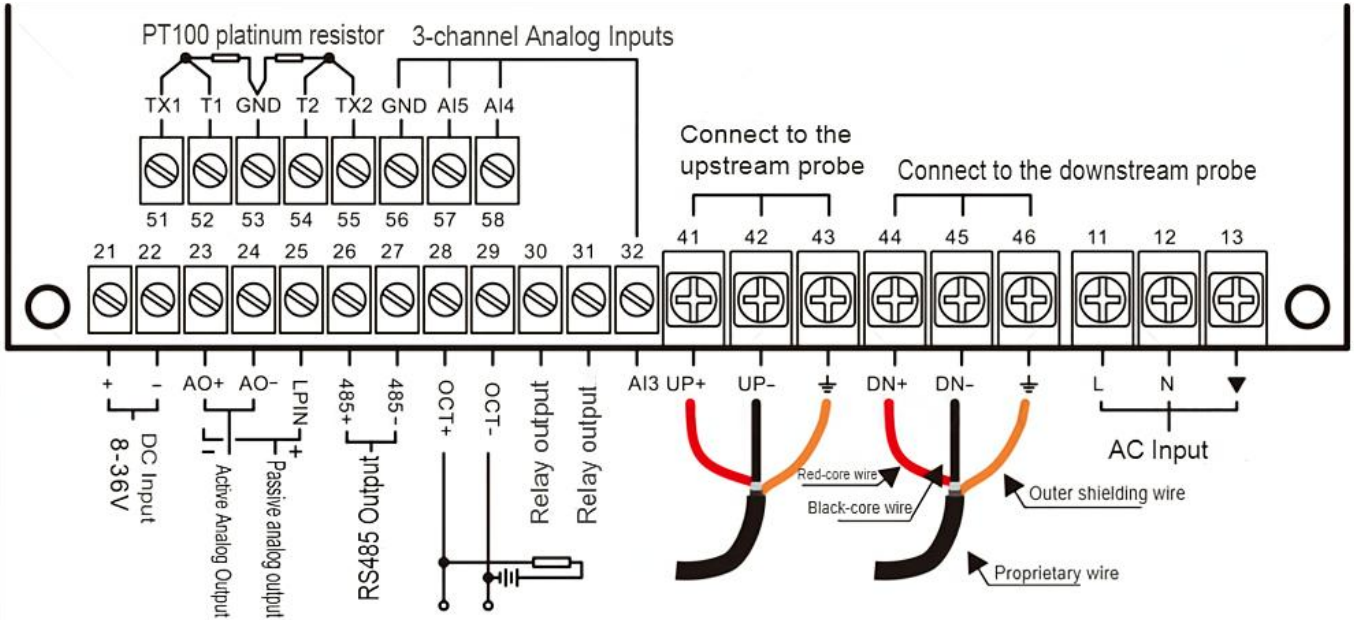

Fig.1 Wall-Mounted Host Terminal Block

① Integrated Host Terminal

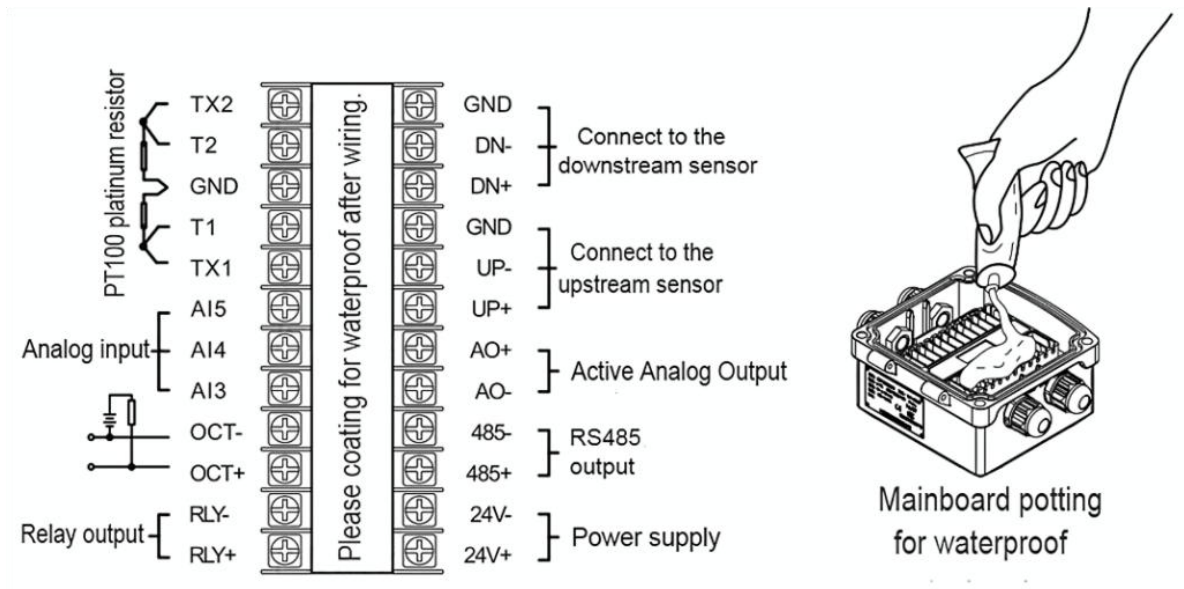

Fig.2 Integrated Host Terminal Block

After opening the cover and wiring, please pot the terminal slots with the provided silicone to make the motherboard waterproof.

- **Terminal Block of Clamp-on Sensor**

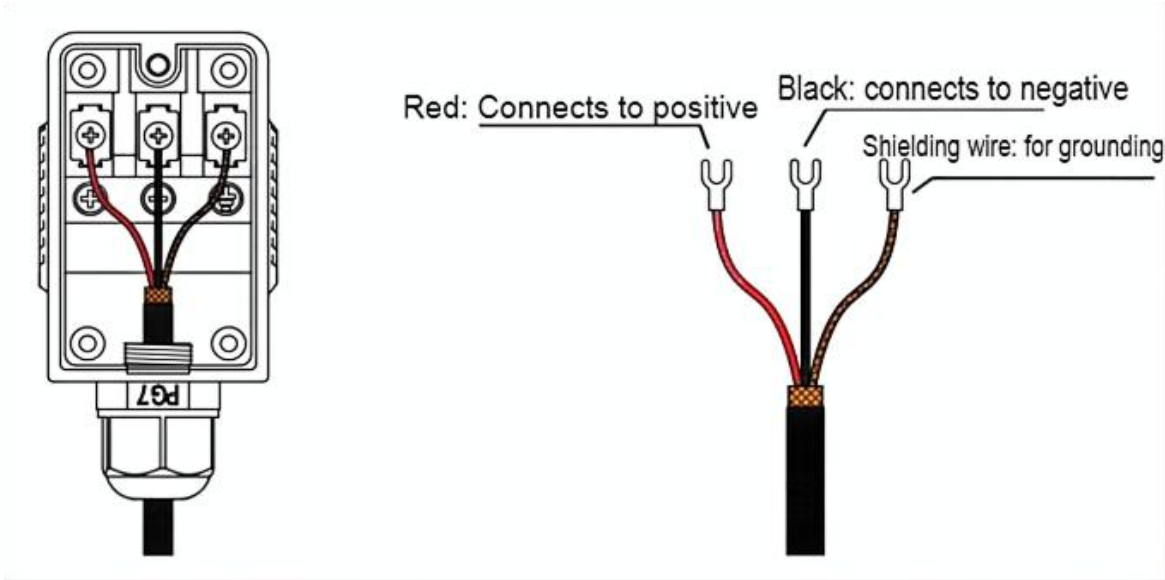

Fig.3 Wiring Diagram Of Clamp-On Sensor

- **Terminal Block of Insertion Sensor**

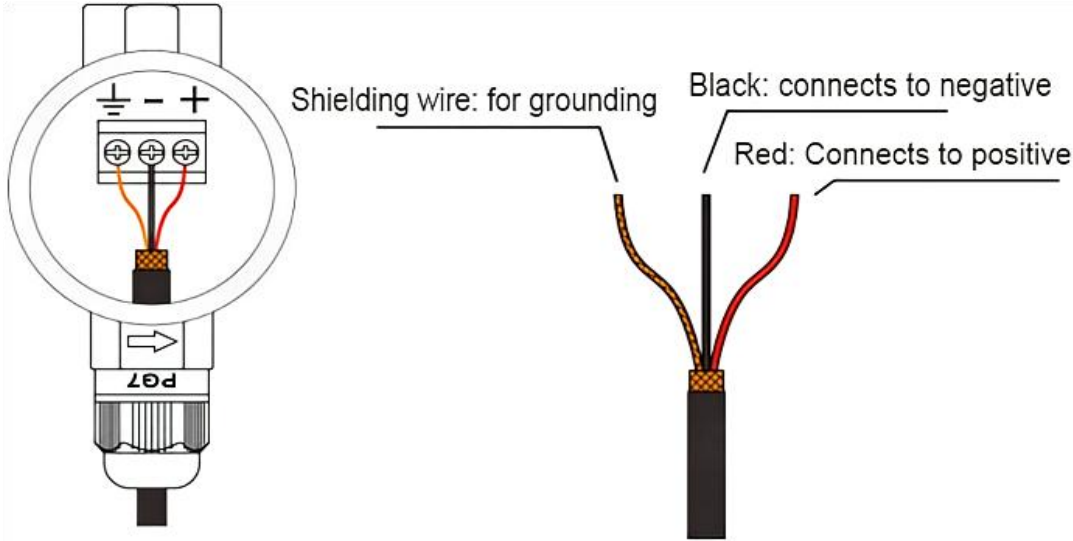

Fig.4 Wiring Diagram Of Insertion Sensor

- **Terminal Block of Inline Sensor**

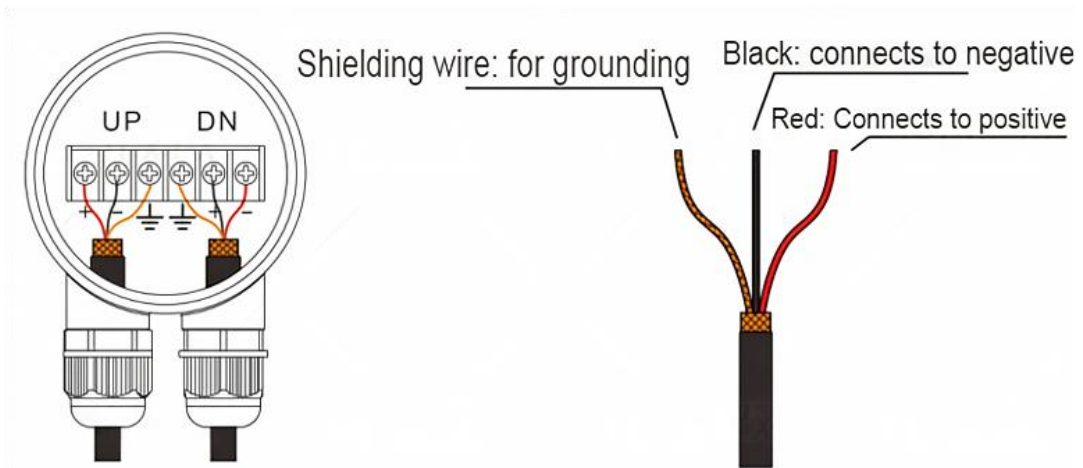

Fig.5 Wiring Diagram Of The Remote Inline Sensor

(2) The Wiring of Host Unit and Sensor

The host and sensors are connected via a dedicated two-core cable provided by us. Since the signals transmitted by the ultrasonic sensors are prone to attenuation and interference, it is essential to use only the dedicated cables we provide and ensure that both cables are of equal length. Please make sure to distinguish between the upstream and downstream sensors: connect the UP port to the upstream sensor and the DN port to the downstream sensor.

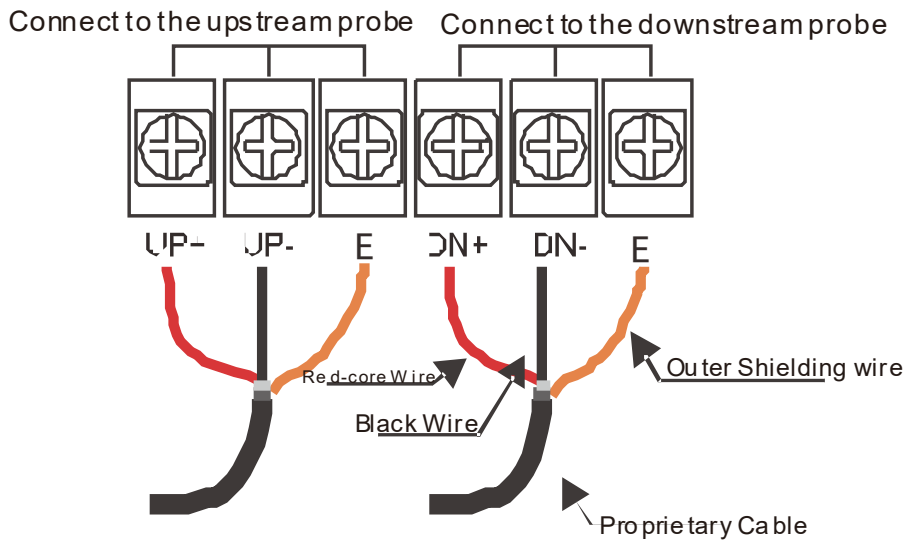
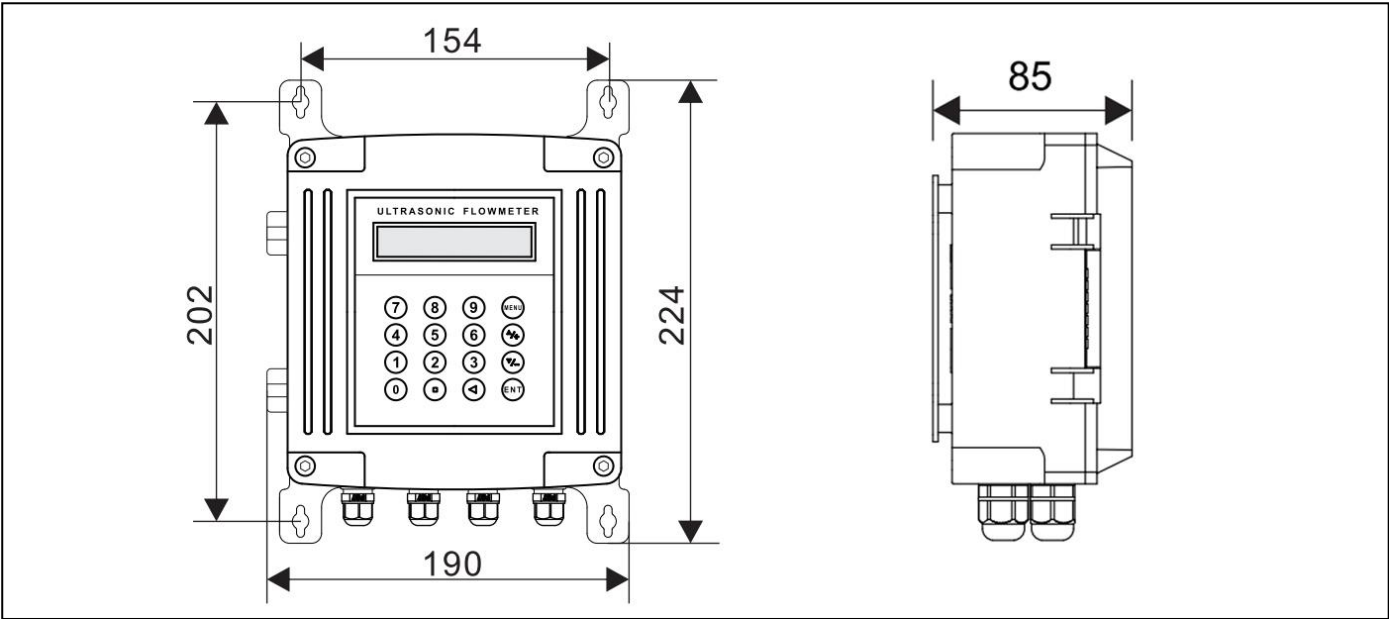

Fig.6 Sensor Connecting To The Host

Dimension



Wall mounted type dimension

Installation

■ Installation

When measuring underground pipes or need to protect the measuring points, an instrument well is required. To ensure the enough installation space, the sizes of instrument well should meet the following requirements.

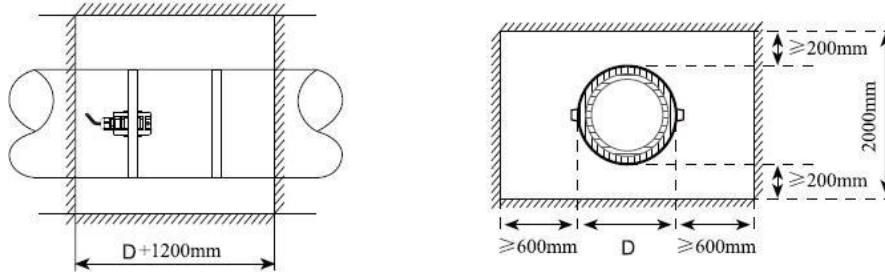

D means the pipe diameter

⚠ Before installation, please verify the parameters of pipeline and liquid. To ensure the installation accuracy.

(1) Installation procedure

Select an installation method → Input the measuring parameters → Clean pipe surface → Install transducers → Check the installation

(2) Select an installation method

There are two different methods for clamp on transducers: V method and Z method.

>> V method

V method should be priority selected for pipe sizes DN15 - DN200. Let the pair of transducers horizontal alignment, the central line in parallel with the pipeline axis.

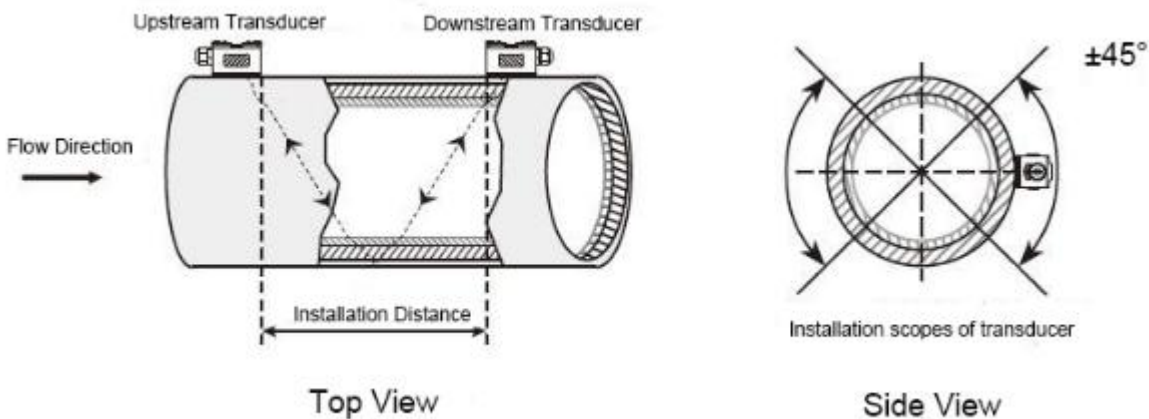

>> Z method

Z method should be priority selected for pipe sizes DN200 - DN6000. Also can be used when V method doesn't work well. Make sure the vertical distance of two transducers equals to the installation distance, and the two transducers are on the same axis surface.

(3) Positioning installation points

>> V method

The line between two transducers is parallel to pipe axis, and equal to the distance shown in the converter. As shown, A, B are the two installation points.

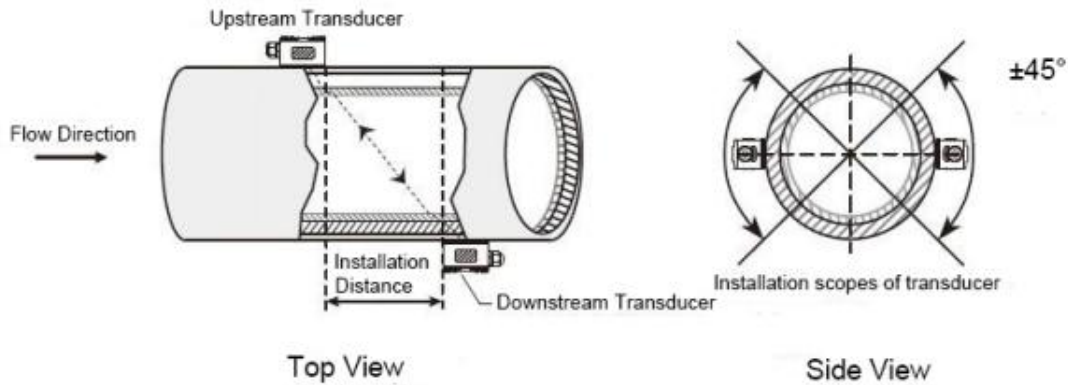

Z method

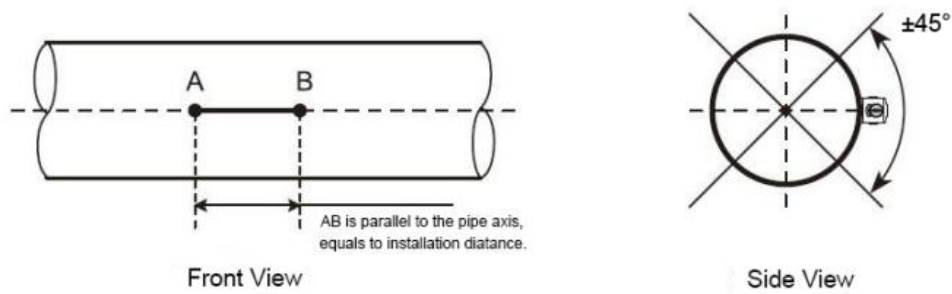

V method

>> Z method

- (1) Firstly according to the installation distance shown in converter, positioning two points A, C on the same side of pipeline. AC is parallel to pipe axis.
 - (2) Perpendicular to the pipe axis, opposite to point C, get Point B.
 - (3) Check. Measure the length between A and B from both sides of the pipe, get AB1 and AB2. If AB1 = AB2, then B is the correct point. If not, need to positioning point B and C again.
- As shown, A, B are the two installation points.

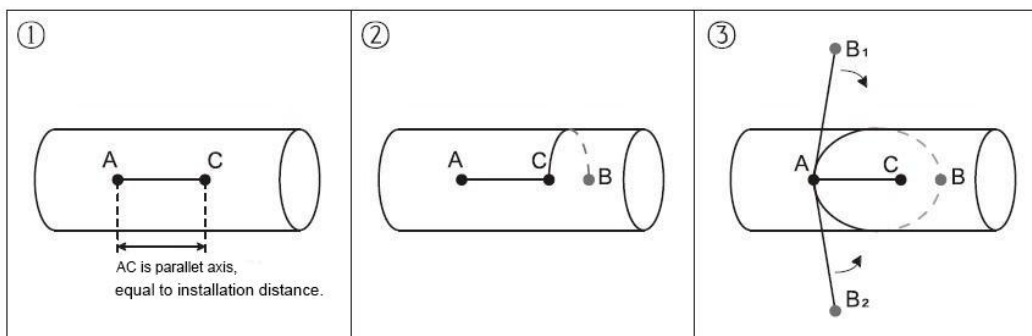

Z method

(4) Clean the surface of installation points

Paint, rust and anti-corrosive coating on installation points need to be cleaned. It's good to use a polishing machine to get the metal luster.

As shown below:

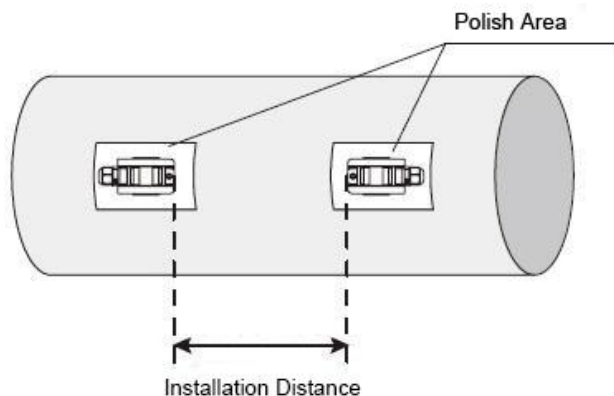

(5) Install transducers

After transducer wiring and sealing, please evenly smear 2-3mm couplant on the transducer emitting surface. Then put the transducers on the installation points, fixed with steel belt or steel rope.

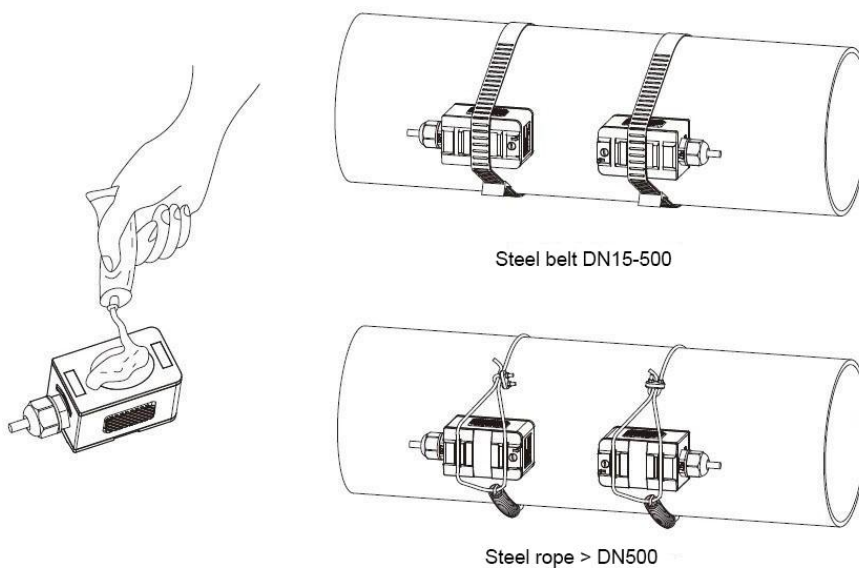

Ordering code

SUP-1158S -W1-T7-L-AD-WL-05-PG						Description
Sensor type	W1					Small external clip type (DN32-DN100)
	W3					Medium external clip type(DN50-DN700)
	W4					Large external clip type(DN300-DN1200)
	Z1					Small bracket (DN20-DN100)
	Z2					Medium bracket(DN50-DN300)
	Z3					Extended bracket(DN300-DN700)
	C1					Standard plug-in(DN80-DN6000)
	C2					Extended plug-in(DN80-DN6000)
	XX					Others
Temperature Resistance Grade		T7				-30-90°C
		FG				-30-130°C
Accuracy			L			1.0 Class
Output and Power Supply				AD		Pulse+4-20mA+RS485+SPST, 24VDC/220VAC Battery Dual Power Supply
Electrical Interface, Housing Material, and Ingress Protection					WL	PG7 Cable Gland, Aluminum Alloy, IP65
					WM	PG7 Cable Gland, Aluminum Alloy, IP68
Cable Length					05	5m
					10	10m
					20	20m
					XX	Others
Accessories					P3	Couplant (90g)
					PH	hole opener + drill
					PJ	Welding base