

## Dual-loop digital display controller

### Supmea

#### Headquarters

5th floor, Building 4, Singapore Hangzhou Science Technology Park, No. 6 street,  
Hangzhou Economic Development Area, Hangzhou 310018, China

#### Singapore

2 Venture Drive #11-30 Vision Exchange Singapore

✉ [info@supmea.com](mailto:info@supmea.com)

🌐 [www.supmea.com](http://www.supmea.com)

Supmea Automation Co., Ltd.

---

## **Preface**

Thank you for purchasing dual-loop digital display controller. Please read this manual carefully before operating and using it correctly to avoid unnecessary losses caused by false operation.

### **Note**

- Modification of this manual's contents will not be notified as a result of some factors, such as function upgrading.
- We try our best to guarantee that the manual content is accurate, if you find something wrong or incorrect, please contact us.
- This product is forbidden to use in explosion-proof occasions.

### **Version**

U-SUP-2200-EN3

---

## Safety Precautions

In order to use this product safely, be sure to follow the safety precautions described.

### About this manual

- Please submit this manual to the operator for reading.
- Please read the operation manual carefully before applying the instrument. On the precondition of full understanding.
- This manual only describes the functions of the product. The company does not guarantee that the product will be suitable for a particular use by the user.

### Precautions for protection, safety and modification of this product

- To ensure safe use of this product and the systems it controls, Please read carefully the operation manual and understand the correct application methods before putting into operation, to avoid unnecessary losses due to operation mistakes. If the instrument is operated in other ways not described in the manual, the protections that the instrument give may be destroyed, and the failures and accidents incurred due to violation of precautions shall not be borne by our company.
- When installing lightning protection devices for this product and its control system, or designing and installing separate safety protection circuits for this product and its control system, it needs to be implemented by other devices.
- If you need to replace parts of the product, please use the model specifications specified by the company.
- This product is not intended for use in systems that are directly related to personal safety. Such as nuclear power equipment, equipment using radioactivity, railway systems, aviation equipment, marine equipment, aviation equipment and medical equipment. If applied, it is the responsibility of the user to use additional equipment or systems to ensure personal safety.
- Do not modify this product.

- 
- The following safety signs are used in this manual:



Hazard, if not taken with appropriate precautions, will result in serious personal injury, product damage or major property damage.



Warning: Pay special attention to the important information linked to product or particular part in the operation manual.



- Confirm if the supply voltage is consistent with the rated voltage before operation.
- Don't use the instrument in a flammable and combustible or steam area.
- To prevent from electric shock, operation mistake, a good grounding protection must be made.
- Thunder prevention engineering facilities must be well managed: the shared grounding network shall be grounded at is-electric level, shielded, wires shall be located rationally, SPD surge protector shall be applied properly.
- Some inner parts may carry high voltage. Do not open the square panel in the front except our company personnel or maintenance personnel acknowledged by our company, to avoid electric shock.
- Cut off electric powers before making any checks, to avoid electric shock.
- Check the condition of the terminal screws regularly. If it is loose, please tighten it before use.
- It is not allowed to disassemble, process, modify or repair the product without authorization, otherwise it may cause abnormal operation, electric shock or fire accident.
- Wipe the product with a dry cotton cloth. Do not use alcohol, benzine or other organic solvents. Prevent all kinds of liquid from splashing on the product. If the product falls into the water, please cut off the power immediately, otherwise there will be leakage, electric shock or even a fire

---

accident.

- Please check the grounding protection status regularly. Do not operate if you think that the protection measures such as grounding protection and fuses are not perfect.
- Ventilation holes on the product housing must be kept clear to avoid malfunctions due to high temperatures, abnormal operation, shortened life and fire.
- Please strictly follow the instructions in this manual, otherwise the product's protective device may be damaged.



- Don't use the instrument if it is found damaged or deformed at opening of package.
- Prevent dust, wire end, iron fines or other objects from entering the instrument during installation, otherwise, it will cause abnormal movement or failure.
- During operation, to modify configuration, signal output, startup, stop, operation safety shall be fully considered. Operation mistakes may lead to failure and even destruction of the instrument and controlled equipment.
- Each part of the instrument has a certain lifetime, which must be maintained and repaired on a regular basis for long-time use.
- The product shall be scrapped as industrial wastes, to prevent environment pollution.
- When not using this product, be sure to turn off the power switch.
- If you find smoke from the product, smell odor, abnormal noise, etc., please turn off the power switch immediately and contact the company in time.

---

## Disclaimer

- The company does not make any guarantees for the terms outside the scope of this product warranty.
- This company is not responsible for damage to the instrument or loss of parts or unpredictable damage caused directly or indirectly by improper operation of the user.

No.	Name	Quantity	Note
1	Dual-loop Digital Display Controller	1	
2	Manual	1	
3	Certificate	1	

After opening the box, please confirm the package contents before starting the operation. If you find that the model and quantity are incorrect or there is physical damage in appearance, please contact us.

---

# Contents

Chapter I Introduction .....	1
Chapter II Specifications .....	2
Chapter III Display Panel and Function Keys .....	4
Chapter IV Standard Wiring .....	6
Chapter V Power Settings .....	7
Chapter VI Parameter Settings .....	9
6.1 Level 1 parameters setting .....	9
6.2 Level 2 parameters setting .....	10
Chapter VII Level 2 Parameters Setting .....	21
Chapter VIII Wiring Diagram .....	25
Chapter IX Print Function .....	28
Chapter X Communication .....	29

## Chapter I Introduction

Dual-loop digital display controller with automatic SMD packaging technology has a strong anti-jamming capability. It can be used in conjunction with various sensors、transmitters to display temperature, pressure, liquid level, speed, force and other physical parameters, and to output alarm control, analog transmission, RS-485/232 communication etc. Designed with dual-screen LED display, you can set the displaying contents of upper and lower screen, and through mathematic function you can make addition, subtraction, multiplication and division to the two input loop input signals, and it has a very good applicability.

## Chapter II Specifications

Table 1

Input				
Input signals	Current	Voltage	Resistance	Thermocouple
Input Impedance	≤250Ω	≥500KΩ		
Maximum input current	≤30mA			
Maximum input voltage		≤6V		
Output				
Output signals	Current	Voltage	Relay	24V Distribution or feeder
Output load capability	≤500Ω	≥250 KΩ (Note: Please replace the module for higher load capacity)	AC220V/0.6 (small) DC24V/0.6A (small) AC220V/3A (big) DC24V/3A (big) According to Remarks	≤30mA
Comprehensive parameter				
Accuracy	0.2%FS ±1 bit			
Setting model	Panel touch key parameter setting values locking; store the setting values permanently			
Display style	-1999 ~ 9999 display range 0 ~ 100% measured value lightness bargraph display; LBD display for working state			

Input				
Input signals	Current	Voltage	Resistance	Thermocouple
Working environment	Ambient temperature: 0 ~ 50 °C; Relative humidity: ≤ 85% RH; Far from strong corrosive gas			
Power supply	AC 100 ~ 240V, (50/60HZ); DC 20 ~ 29V			
Power	≤5W			
Frame	Standard snap-on			
Communication	Standard MODBUS communication protocol, RS-485, communication distance up to 1 km, RS-232 ,communication distance up to 15 meters Note: While with communication function, the communication converter should be a active one.			

Note: The output load capacity of external dimensions D, E,H instrument relay is the AC220V/0.6A, DC24V/0.6A

## Chapter III Display Panel and Function Keys



Fig. 1

### 1) Instrument dimension and hole size:

Table 2

Dimensions/code	Hole Size
160*80mm (Horizontal )/A	152*76mm
80*160mm (Vertical )/B	76*152mm
96*96mm (squarely)/C	92*92mm
96*48mm (Horizontal)/D	92*45mm
48*96mm (Vertical)/E	45*92mm
72*72mm (squarely)/F	68*68mm
160*80mm (Horizontal / beam)/K	152*76mm
80*160mm (Vertical / beam)/L	76*152mm





### 2) Digital display window:

PV display window: display the value of Loop 1 signals; you can set the displaying content as your choice. In the state of parameters setting, display parameter symbols.

SV display window: display the value of Loop 2 signals; you can set the displaying content as your choice. In the state of parameters setting, display parameter symbols.

## 3) Buttons

Table 3

	Enter key: conformation for parameters update Page Down: Page down for parameter settings Exit key: Return to measurement screen pressed for 2 seconds
	Shift key: Shift to the left one bit every press; Return key: Return to a the upper parameters pressed for 2 seconds
	Minus key: used to reduce the value; display time, under print function
	Plus key: increase the value; display time under print function

## 4) 4 Indicators

1AL1: Alarm 1 indicator for Loop 1

1AL2: Alarm 2 indicator for Loop 1

2AL1: Alarm 1 indicator for Loop 2

2AL2: Alarm 2 indicator for Loop 2

## Chapter IV Standard Wiring

You should pay attention to the following items when wire the instruments

PV input (process signal input)

1. To reduce electrical interference, the low-voltage DC signal and sensor input wire should stay away from strong electrical wire. If not, you should use shielded wire, and ground it at one point.

2. Any device between the sensor and terminal, maybe affects the measurement accuracy due to resistance or leakage current

Thermocouple or pyrometer input:

You should use the compensation wires corresponding for the thermocouple as extension wire, and it's the best if the wire is shielding.







RTD (platinum resistance) input:





The resistance for the 3 wire must be the same, and each wire must not exceed  $15\Omega$  resistor

## Chapter V Power Settings

As soon as instrumentation is powered on, it enters into the self-testing status (seen in the right), and when self- testing is completed, it automatically transfers to the working state.

In the working state, press the button  and it displays LOC, LOC parameter settings are listed in the following:

1. 1) You can enter into Level 1 menu whatever the Loc is (LOC = 00、132, no locking function);
- 2) when Loc is 132, press button  for 4 seconds to enter Level 2 menu;
- 3) when Loc is 130, press button  for 4 seconds to enter the time setting menu, only for the instruments with printing capability.
- 4) when Loc is others, press the button  for 4 seconds to return to the measuring state.
2. If Loc is 577, in the Loc menu, press the key  and  for 4 seconds at the same time, you can restore all the parameters to factory default settings.
3. In any other menu, press the button  for 4 seconds to exit to the measuring screen.
4. When thermocouple signal as input and channel decimal dP is 0, the temperature resolution is 1 °C; when dP is 1, the temperature resolution is 0.1 °C, (resolution automatically changed to 1 °C when the temperature is over 1000 °C).
5. Time setting

In the state of PV displaying measured values, press the button  to enter parameters setting, set LOC as 130; In the state of PV displaying LOC and SV displaying 130, press button  for 4 seconds to enter into the time parameter settings. When PV displays "dATE " and SV displays the current date (for example :090720-July 20, 2009) set the current date in the same way as parameters settings. In the state of current time, press the key , PV displays "TInE" and SV displays the current time (for example, 183047-18:30:47), set the current time in the same way as parameters settings. In the state of current time, press the button  again to exit time setting to PV measuring screen.

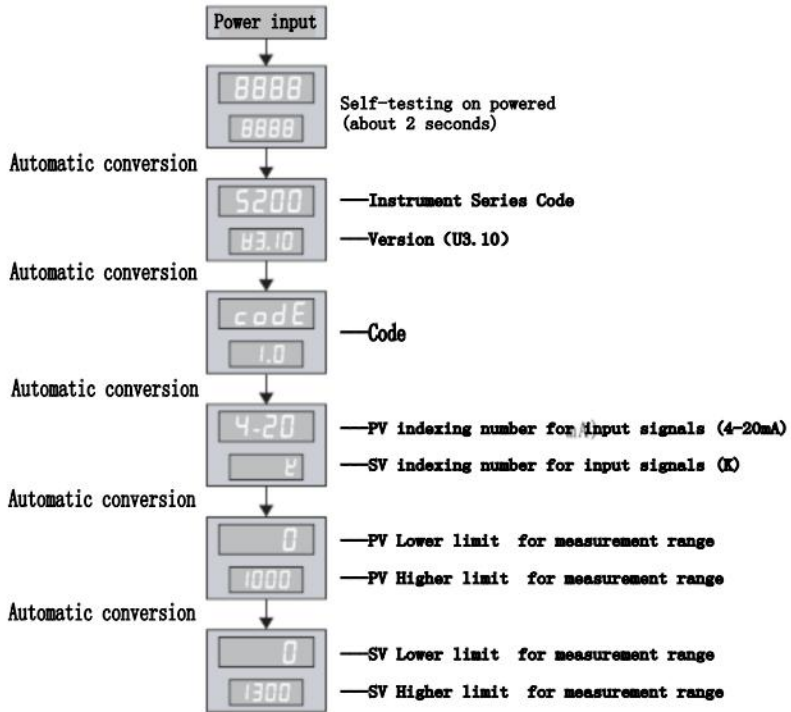

Fig. 2

★ Back to working status

1. Manual way: In the state of parameters setting, press the button for 4 seconds, the instrument will automatically return to real-time measurement state.
2. Auto way: In the state of parameters setting, do not press any button. After 30 seconds the instrument will automatically return to real-time measurement state.

## Chapter VI Parameter Settings

### 6.1 Level 1 parameters setting











In the working state, press button  and PV displays LOC, SV displays the parameter values: Press  or  to set parameters. Press button  for 2 seconds to return to upper level parameter, when Loc is any value. You can enter into Level 1 parameter setting.

Table 4

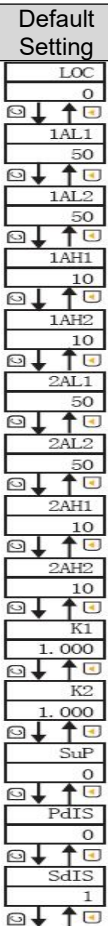
Default Setting	Parameters	Setting Range	Description
	<p><b>Loc</b></p> <p>Parameters locking</p>	0~999	<p>LOC=00: No locking (Level 1 parameters can be modified)</p> <p>LOC≠00、132: Locking (Level 1 parameters can not be modified)</p> <p>LOC=132: No locking, into Level 2 parameters setting (Level 1 parameters can be modified)</p>
	<p><b>1AL1</b></p> <p>Set point of Alarm 1 for Loop 1</p>	-1999~9999	Set point of Alarm 1 for Loop 1
	<p><b>1AL2</b></p> <p>Set point of Alarm 2 for Loop 1</p>	-1999~9999	Set point of Alarm 2 for Loop 1
	<p><b>1AH1</b></p> <p>Difference of Alarm 1 for Loop 1</p>	0~9999	Difference of Alarm 1 for Loop 1
	<p><b>1AH2</b></p> <p>Difference of Alarm 2 for Loop 1</p>	0~9999	Difference of Alarm 2 for Loop 1
	<p><b>2AL1</b></p> <p>Set point of Alarm 1 for Loop 2</p>	-1999~9999	Set point of Alarm 1 for Loop 2
	<p><b>2AL2</b></p> <p>Set point of Alarm 2 for Loop 2</p>	-1999~9999	Set point of Alarm 2 for Loop 2
	<p><b>2AH1</b></p> <p>Difference of Alarm 1 for Loop 2</p>	0~9999	Difference of Alarm 1 for Loop 2

Default Setting	Parameters	Setting Range	Description
Return to the original screen LOC	 Difference of Alarm 2 for Loop 2	0~9999	Difference of Alarm 2 for Loop 2
	 Input signal coefficient of Loop 1	-1.999~9.999	Input signal coefficient of Loop 1
	 Input signal coefficient of Loop 2	-1.999~9.999	Input signal coefficient of Loop 2
	Mathematic symbols	0~2	0: multiplication 1: division 2: addition
	 PV displaying style	0~3	0: PV displays the measured value of Loop1 1: PV displays the measured value of Loop2 2: PV displays the mathematic functions of the two loops 3: PV displays the measured values and the mathematic functions of the two loops circularly
 SV screen displaying contents	0~3	0: PV displays the measured value of Loop1 1: PV displays the measured value of Loop2 2: PV displays the mathematic functions of the two loops 3: PV displays the measured values and the mathematic functions of the two loops circularly	

## 6.2 Level 2 parameters setting

























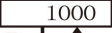

In the working state, press button  and PV displays LOC, SV displays parameter values; Press  or  to set parameters. Press the button  for 2 seconds to back to the upper parameters setting; when Loc is 132, press button  for 4 seconds, you can enter into Level 2 parameters setting.

Table 5

Default Setting	Parameters	Setting Rang(word)	Description
Addr 1	<i>Addr</i> Device ID	0~250	Set the ID of the instrument in communication
bAud 3	<i>bAud</i> Communication baud rate	0~3	Baud = 0: Communication baud is 1200bps; Baud = 1: Communication baud is 2400bps Baud = 2: Communication baud is 4800bps; Baud = 3: Communication baud is 9600bps
Pr-A 0	<i>Pr-A</i> Alarm printing function	0~1	0: no alarm printing function (no this parameter when no this function) 1: Alarm printing function (no this parameter when no this function)
IPn 27	<i>Pr-t</i> Interval of printing	10~2400 minutes	Set the interval of printing (when interval is less than 10, no printing) (no this parameter when no this function)
1u 0	<i>Pr-u</i> Printing unit	0~25	Details seen in unit setting function code Table (no this parameter when no this function)
1AM1 2	<i>IPn</i> Indexing number of Loop 1	0~35	Set the input index number types (see dividing type table)
1ALG 0	<i>IdP</i> Decimal point of Loop 1	0~3	dP=0: No decimal point dP=1: Decimal point in the ten (Displaying XXX.X) dP=2: Decimal point in the hundred (Displaying XX.XX) dP=3: Decimal point in the thousand (Displaying X.XXX)
1ALM 01	<i>Iu</i> Unit of Loop 1	0~45	Details seen in Unit setting Function Code Table
	<i>IRn 1</i>	0~2	X = 0: following the first alarm

Default Setting	Parameters	Setting Rang(word)	Description
	First limited alarming mode		X = 1: following the second alarm X = 2: following the calculation result alarm Y = 0: no alarm Y = 1: lower limit alarm Y = 2: upper limit alarm
	<b>1A22</b> Second limited alarming mode	0~2	X = 0: following the first alarm X = 1: following the second alarm X = 2: following the calculation result alarm Y = 0: no alarm Y = 1: lower limit alarm Y = 2: upper limit alarm
	<b>1ALG</b> Ficker alarm of Loop 1	0~1	1ALG=0: no flicker alarming 1ALG=1: flicker alarming
	<b>1FE</b> Filtrate coefficient	0~19	Setting filter coefficients to prevent value flicking (seen in instrument parameters description 2)
	<b>1ALn</b> Alarm function of Loop 1	0~19	one = 0: No alarm delay function one = 1-9: delay (0.5 × value set) seconds and then output alarm signals ten = 0: Alarm when off-line (relay contact alarm output) ten = 1: No alarm when off-line (Note: When ALM4 is 3, this function is invalid)

Table 6

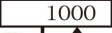
Default Setting	Parameters	Setting Rang(word)	Description
1brK 01  1Pb 0  1PK 1.000  1Cb 0  1CK 1.000  1oub 0.000  1ouk 1.000  1ouL 0  1ouH 1000  1GL 0  1GH 1000  1ZL 0  1ZH 1000 	brK Display value when off-line	0~3	Brk = 0: Displaying 0 when off-line Brk = 1: Displaying maximum indexing number value when off-line Brk = 2: Displaying maximum value before when off-line Brk = 3: Displaying then value before off-line
1Cb 0 	1Pb Zero shift of Loop 1 display value	Full range	Set the zero shift range of input signals (seen in instrument parameters Description 3)
1CK 1.000 	1PE Proportion of the input range of Loop 1	0~1.999	Set the proportion of input range (seen in the instrument parameters Description 3)
1oub 0.000 	1Cb Zero shift of Loop 1 cold-junction compensation	Full range	Set the zero shift range of cold-junction compensation (only for thermocouple signals)
1ouk 1.000 	1CE Proportion of the input range of Loop 1	0~1.999	Set amplification of cold-junction compensation (only for thermocouple signals)
1ouL 0  1ouH 1000 	1oub Zero shift of Loop 1 transmission output	0~1.2	Setting the zero shift range of transmission output 1 (seen in the instrument parameters Description 4)
1GL 0  1GH 1000 	1ouE Amplification of Loop 1 transmission output	0~1.2	Set the amplification of transmission output 1 (seen in the instrument parameters Description 4)
1ZL 0  1ZH 1000 	1ouL lower limit of Loop 1 transmission output range	Full range	Set the lower limit of the transmission output range













Default Setting	Parameters	Setting Rang(word)	Description
	 upper limit of Loop 1 transmission output range	Full range	Set the upper limit of the transmission output range
	 Lower limit of Loop 1 flicker alarm	Full range	Set the lower limit of flicker alarm range (when measured value is lower than set value, the measured value flickers ; this function exists when ALG=1)
	 Upper limit of Loop 1 flicker alarm	Full range	Set the upper limit of flicker alarm range (when measured value is higher than set value, the measured value flickers ; this function exists when ALG=1)
	 Lower limit of PV Bargraph	Full range	Set the lower limit of bargraph (only for bargraph) (Seen in Instrument Parameter Description 5)
	 Upper limit of PV Bargraph	Full range	Set the upper limit of bargraph (only for bargraph) (Seen in Instrument Parameter Description 5)

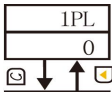
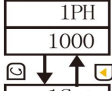
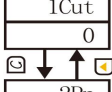
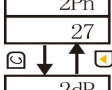
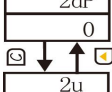
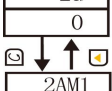
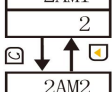
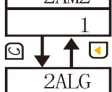



Table 7

Default Setting	Parameters	Setting Rang(word)	Description
 <p>1PL 0</p>	Lower limit of Loop 1 measurement range	Full range	Set the lower limit of input signal
 <p>1PH 1000</p>	Upper limit of Loop 1 measurement range	Full range	Set the upper limit of input signal
 <p>1Cut 0</p>	Loop 1 small input signal excision	0~100%	Set small input signal excision range (When input signal is lower than set point , it displays 0. This function only for voltage or current signals)
 <p>2Pn 27</p>	Indexing number of Loop 2	0~35	Set the input index number types (see dividing type table)
 <p>2dP 0</p>	Decimal point of Loop 2	0~3	dP=0: No decimal point dP=1: Decimal point in the ten (Displaying XXX.X) dP=2: Decimal point in the hundred ( Displaying XX.XX) dP=3:Decimal point in the thousand ( Displaying X.XXX)
 <p>2u 0</p>	Unit of Loop 2	0~45	Details seen in Unit setting Function Code Table
 <p>2ALM 01</p>	Third limited alarming mode	0~2	X = 0: following the first alarm X = 1: following the second alarm X = 2: following the calculation result alarm Y = 0: no alarm Y = 1: lower limit alarm Y = 2: upper limit alarm
 <p>2ALM2 1</p>	Fourth limited alarming mode	0~2	X = 0: following the first alarm X = 1: following the second

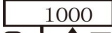
Default Setting	Parameters	Setting Rang(word)	Description
	alarming mode		alarm X = 2: following the calculation result alarm Y = 0: no alarm Y = 1: lower limit alarm Y = 2: upper limit alarm
	<b>2ALG</b> Ficker alarm of Loop 2	0~1	2ALG=0: no flicker alarming 2ALG=1: flicker alarming
	<b>2FE</b> Filtrate coefficient	0~19	Setting filter coefficients to prevent value flicking (seen in instrument parameters description 2)
	<b>2ALn</b> Alarm function of Loop 2	0~19	one = 0: No alarm delay function one = 1-9: delay (0.5 × value set) seconds and then output alarm signals ten = 0: Alarm when off-line (relay contact alarm output) ten = 1: No alarm when off-line (Note: When ALM4 is 3, this function is invalid)
	<b>2BrL</b> Loop 2 display value when off-line	0~3	Brk = 0: Displaying 0 when off-line Brk = 1: Displaying maximum indexing number value when off-line Brk = 2: Displaying maximum value before when off-line Brk = 3: Displaying then value before off-line
	<b>2PB</b> Zero shift of Loop 2display value	Full range	Set the zero shift range of input signals (seen in instrument parameters Description 3)

Table 8

Default Setting	Parameters	Setting Rang(word)	Description
2PK 1.000 	2P4 Proportion of the input range of Loop 2	0~1.999	Set the proportion of input range (seen in the instrument parameters Description 3)
2Cb 0 	2Cb Zero shift of Loop 2 cold-junction compensation	Full range	Set the zero shift range of cold-junction compensation (only for thermocouple signals)
2CK 1.000 	2C4 Amplification of Loop 2 cold-junction compensation	Full range	Set the amplification of cold-junction compensation (only for thermocouple signals)
2oub 0.000 	2oub Zero shift of Loop 2 transmission output	0~1.2	Setting the zero shift range of transmission output (seen in the instrument parameters Description 4)
2ouK 1.000 	2ouK Amplification of Loop 2 transmission output	0~1.2	Set the amplification of transmission output (seen in the instrument parameters Description 4)
2ouL 0 	2ouL lower limit of Loop 2 transmission output range	Full range	Set the lower limit of the transmission output range
2ouH 1000 	2ouH upper limit of Loop 2 transmission output range	Full range	Set the upper limit of the transmission output range
2GL 0 	2GL Lower limit of Loop 2 flicker alarm	Full range	Set the lower limit of flicker alarm range (when measured value is lower than set value, the measured value flickers ; this function exists when ALG=1)
2GH 1000 	2GH Set the upper limit of flicker	Full range	

Default Setting	Parameters	Setting Rang(word)	Description
Return to the original screen Addr	Upper limit of Loop 2 flicker alarm		alarm range (when measured value is higher than set value, the measured value flickers ; this function exists when ALG=1)
	 Lower limit of PV Bargraph	Full range	Set the lower limit of bargraph (only for bargraph) (Seen in Instrument Parameter Description 5)
	 Upper limit of PV Bargraph	Full range	Set the upper limit of bargraph (only for bargraph) (Seen in Instrument Parameter Description 5)
	 Lower limit of Loop 2 measurement range	Full range	Set the lower limit of input signal
	 Upper limit of Loop 2 measurement range	Full range	Set the upper limit of input signal
	 Loop 2 small input signal excision	0~100%	Set small input signal excision range (When input signal is lower than set point , it displays 0. This function only for voltage or current signals)

## ★Input signal types table:

Table 9

Degree no .Pn	Signal Types	Measuring Range	Degree no Pn	Signal Types	Measuring Range
0	Thermocoupl B	400~ 1800℃	18	Remote Resistance 0~350Ω	-1999~ 9999
1	Thermocoupl S	0~1600℃	19	Remote Resistance 3 0~350Ω	-1999~ 9999
2	Thermocoupl K	0~1300℃	20	0~20mV	-1999~ 9999
3	Thermocoupl E	0~1000℃	21	0~40mV	-1999~ 9999
4	Thermocoupl T	-200.0~ 400.0℃	22	0~100mV	-1999~ 9999
5	Thermocoupl J	0~1200℃	23	-20~20mV	-1999~ 9999
6	Thermocoupl R	0~1600℃	24	-100~ 100mV	-1999~ 9999
7	Thermocoupl N	0~1300℃	25	0~20mA	-1999~ 9999
8	F2	700~ 2000℃	26	0~10mA	-1999~ 9999
9	Thermocouple Wre3-25	0~2300℃	27	4~20mA	-1999~ 9999
10	Thermocouple Wre5-26	0~2300℃	28	0~5V	-1999~ 9999
11	RTD Cu50	-50.0~ 150.0℃	29	1~5V	-1999~ 9999
12	RTD Cu53	-50.0~ 150.0℃	30	-5~5V	-1999~ 9999
13	RTD Cu100	-50.0~ 150.0℃	31	0~10V	-1999~ 9999
14	RTD Pt100	-200.0~ 650.0℃	32	0~10mA square	-1999~ 9999
15	RTD BA1	-200.0~ 600.0℃	33	4~20mA square	-1999~ 9999
16	RTD BA2	-200.0~	34	0~5V square	-1999~

Degree no .Pn	Signal Types	Measuring Range	Degree no Pn	Signal Types	Measuring Range
		600.0℃			9999
17	Linear resistance 0~400Ω	-1999~9999	35	1~5V square	-1999~9999

★Unit Setting Function Code Table:

Table 10

Code	0	1	2	3	4	5	6	7	8	9
Unit	kgf	Pa	KPa	MPa	mmHg	mmH <sub>2</sub> O	bar	℃	%	Hz
Code	10	11	12	13	14	15	16	17	18	19
Unit	m	t	l	m <sup>3</sup>	kg	J	MJ	GJ	Nm <sub>3</sub>	m/h
Code	20	21	22	23	24	25	26	27	28	29
Unit	t/h	l/h	m <sup>3</sup> /h	Kg/h	J/h	MJ/h	GJ/h	Nm <sup>3</sup> /h	m/m	t/m
Code	30	31	32	33	34	35	36	37	38	39
Unit	l/m	m <sup>3</sup> /m	Kg/m	J/m	MJ/M	GJ/m	Nm <sup>3</sup> /m	m/s	t/s	l/s
Code	40	41	42	43	44	45				
Unit	m <sup>3</sup> /s	Kg/s	J/s	MJ/s	GJ/s	Nm <sup>3</sup> /s				

## Chapter VII Level 2 Parameters Setting

1. Alarm output (AL1, AL2, AH1, AH2)

★ About difference:

This instrument uses alarm output with difference in order to prevent the frequent action when output relay or alarm output value is near the setting point.

Specific output state is listed as follows:

★ measured values arises:

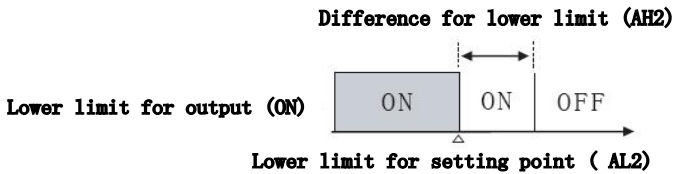

Fig. 3

★ measured values decreases:

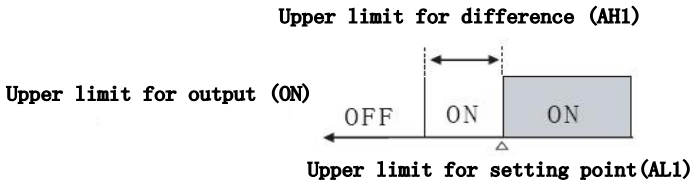

Fig. 4

★ Upper limit of position alarm output:

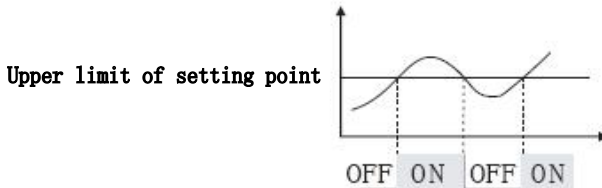

Fig. 5

★Lower limit of position alarm output:

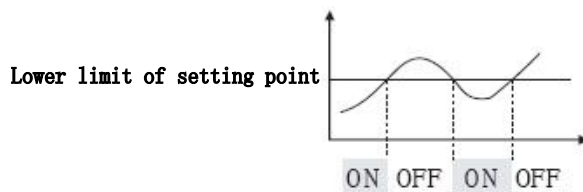

Fig. 6

## 2. Filter coefficient

The times of sampling, used to prevent the flicking of measured values;  
 Sampling period – analog signals as input, the interval of each data acquisition is 0.5 seconds. The relation of PV displaying value, filter coefficient and sampling period is listed as followed:

Example: Analog signals as input, supposing the filter coefficient equals 6 (time), then the instrument will automatically average the input signals during(6 × 0.5) 3 seconds, and refresh PV display value. (Namely displaying the average value of the input signals during front 3 seconds )

## 3. Display shift and amplification of input signals:

In regular modification, you can adjust the value of Pb and Pk to change the display error of measured value.

The formula of Pb and Pk:

$Pk = \frac{\text{the setting display range}}{\text{real display range}} \times \text{original Pk}$

$Pb = \frac{\text{the lower limit of setting display range} - \text{the lower limit of real display range}}{\text{original Pk}} + \text{original Pb}$

Example:

4 ~ 20mA DC current as input signal, measured range = 200 ~ 1000 KPa, and then we make regular modification and find that when input is 4 mA, it displays -202; when input is 20 mA, it displays 1008. (Original Pb = 0, original Pk = 1.000)

According to the formula :

$Pk = \frac{\text{setting display range}}{\text{real display range}} \times \text{original Pk}$   
 $= \frac{[1000 - (-200)]}{(1008 - (-202))} \times 1 = \frac{1200}{1210} \approx 0.992$

$P_b$  = the lower limit of setting display range – the lower limit of real display range ×  $P_k$  + original

$$P_b = -200 - (-202 \times 0.992) + 0 = 0.384$$

Supposing:  $P_b = 0.384$ ,  $P_k = 0.992$

4. Zero shift of transmission output 10ub, 10uK, 20ub, 20uK

Please base 0 ~ 20mA or 0 ~ 5V to make modification to this instrument. If you want make a change to output range or output error, you can refer to the following formula:

$$\text{New Oub} = \text{Current Oub} - \frac{\text{Current output lower limit} - \text{Set output lower limit}}{\text{Full scale}}$$

$$\text{New OuK} = \text{Current OuK} - \frac{\text{Current output Upper limit} - \text{Set output Upper limit}}{\text{Full scale}}$$

In this formula, when the output is current signal, full scale = 20mA; when the output is voltage signal, full scale = 5V.

Example 1:

Transmission current 0 ~ 20mA as output, and we want to change it to 4 ~ 20mA.

We measure that when output zero is 0 mA, if the input is full scale, that output is 20 mA. Current Oub = 0, and current OuK = 1.

$$\text{New Oub} = 0 - \frac{0-4}{20} = 0.2$$

$$\text{New OuK} = 1 - \frac{20-20}{20} = 1$$

Therefore, set Oub as 0,2, and keep OuK unchanged, we have changed the output from 0 ~ 20mA to 4 ~ 20mA.

5. Bargraph display:

Bargraph display: If measurement range is 0 ~ 100 and the current measured value

is 50, then the light beam lights from 0 to 50.

Bargraph display range: bargraph display range is the percentage ZL, ZH.

For example:

- 1) Set the range as 0 ~ 100, if the current measured value is 50, then the light beam displays 50%.
- 2) Set the range as 0 ~ 1000, if the current measured value is 500, then the light beam displays 50%.
- 3) Set the range as 0 ~ 2000, if the current measured value is 1000, then the light beam displays 50%.

## Chapter VIII Wiring Diagram

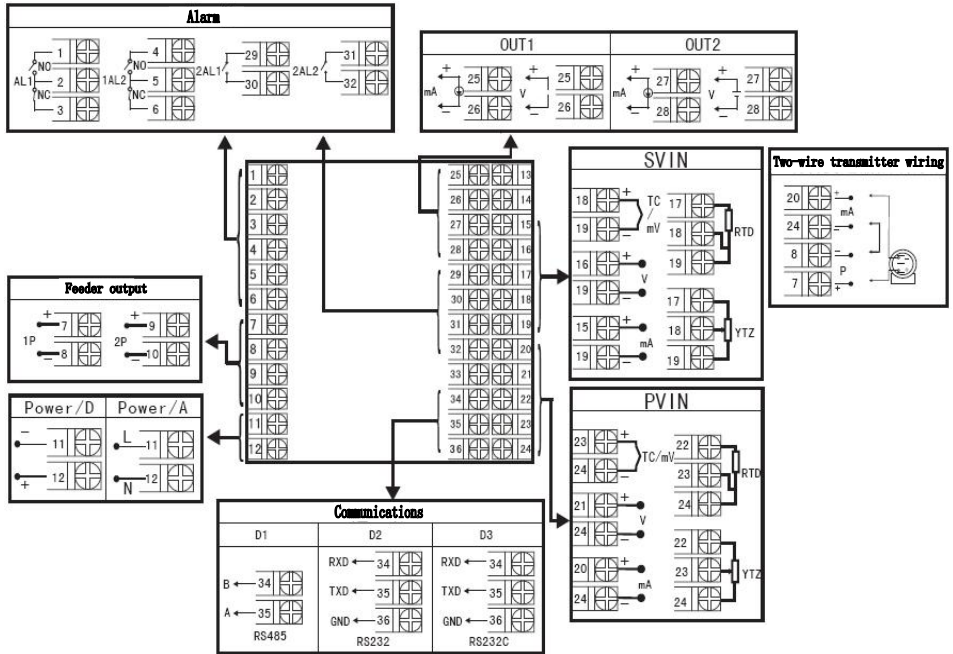

Fig. 7 A, B, C, D, E, K, L, M-type

Note: The horizon and vertical device cover terminal block wirings are different, seen in diagram 1:

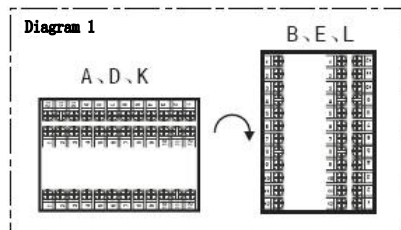

Fig. 8

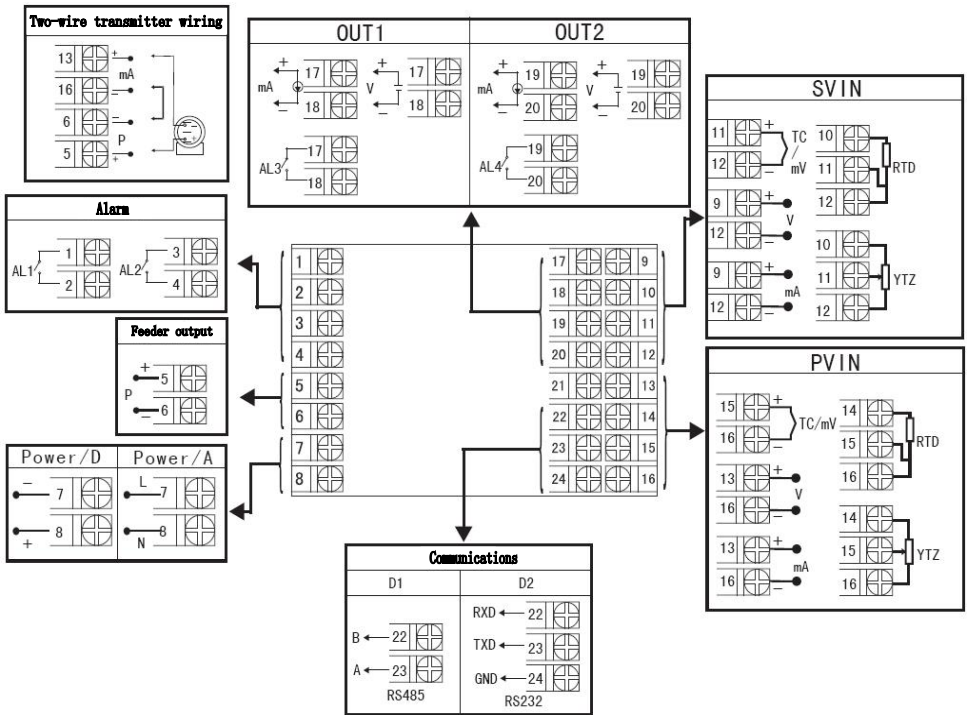

Fig. 9 F-type

Note: With two way feeder outputs, the ground terminals of input current signal terminal should be shorted (pin 19 and 24)

Note: Voltage and current signals of Type F must be switched through the short circuit ring

J1, J2 for Loop 1 input signal switch positions

J3, J4 for Loop 2 input signal switch positions

Table 11

	DC voltage input	DC Current Input
Short-circuit-ring	 V mA	 V mA

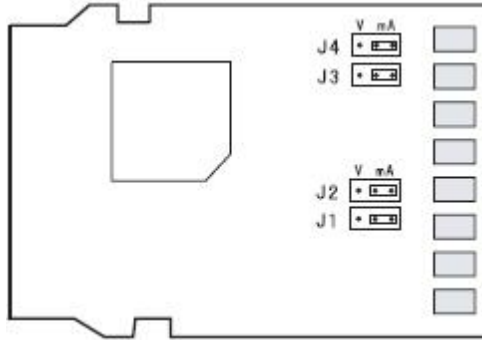



Fig. 10 Type F

## Chapter IX Print Function

### 1. Manual print

In the state of measuring screen, press the button  to print the current real-time measured values.

### 2. Regular print

Every interval time, the instrument will control the printer to print the current real-time measured values. Printing format as followed:

```
-----  
TIME PRINT  
2009-05-16          -----Date  
09: 46: 03         -----Time  
PV=-250℃          -----Measured values of Loop 1  
SV=-250℃          ----- Measured values of Loop 2  
ALM: ○●○○●       ----- Alarm Status  
-----
```

### 3. Wiring

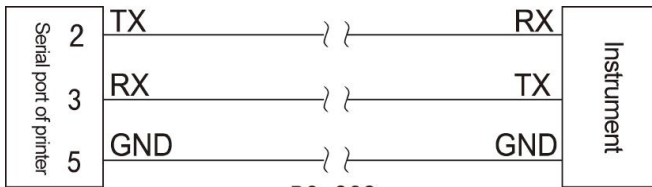

RS-232  
Fig. 11

## Chapter X Communication

This instrument has the ability to communicate with upper computer, and the upper computer can complete the automatic adjustment, parameters setting, data collection and watch of the lower instruments. With the corresponding software, you can finish dynamic picture displaying, parameters setting, diagram printing, logging and report printing and so on in Windows. You can communicate with RS-485, RS-232 in 1200~9600 bps. The data format is: one starting bit, eight data bits and one stopping bit.

★ Specific parameters seen in the "Instrument Communication Handbook"

This instrument can be used with a variety of equipment with serial input and output.