

Online Turbidity Analyzer



Supmea

Headquarters

5th floor, Building 4, Singapore Hangzhou Science Technology Park, No. 6 street, Hangzhou Economic Development Area, Hangzhou 310018, China

Singapore

2 Venture Drive #11-30 Vision Exchange Singapore

✉ info@supmea.com

🌐 www.supmea.com

Supmea Automation Co.,Ltd.

Table of Contents

Chapter 1 Product Overview	1
1.1 Product Information	1
1.1.1 Turbidity Sensor	1
1.1.2 Turbidity transmitter	2
1.2 Safety Information	3
Chapter 2 Installation	4
2.1 Transmitter Installtion	4
2.1.1 Installation Components and Size	4
2.1.2 Installation Instructions	5
2.1.3 Wiring Installation	8
2.1.4 Power Supply Wiring	9
2.1.5 Relay	9
2.1.6 Analog Output	10
2.2 Installation of Sensor	10
2.2.1 Connection of Sensor	10
2.2.2 Installation of Sensors	11
Chapter 3 Product Interface and Operation	12
3.1 The User Interface	12
3.2 The Main Screen	13
3.3 Control Set	13
3.3.1 Device Information	13
3.3.2 Current Output	13
3.3.3 SETUP	14

Turbidity Online Analyzer Operation Manual

3.4 Parameters Setting	19
Chapter 4 Calibration of Sensor	20
Chapter 5 Maintenance	21
5.1 Maintenance of Transmitter	21
5.2 Maintenance of Sensor	21
5.2.1 Status of Sensor	21
5.2.2 Sensor Cleaning	23
5.3 Inspection on the Damage of Sensor	23
5.4 Sensor Blade Replacement	23
5.5 Fuse Replacement	24
Chapter 6 Errors and Warning	25
Chapter 7 Problems and Solutions	26

Chapter 1 Product Overview

1.1 Product Information

1.1.1 Turbidity Sensor

The sensor, based on the infrared absorption scattered light method and combined with the application of ISO7027 method, can guarantee the continuous and accurate detection of turbidity. Based on ISO7027, infrared double scattering light technology will not be affected by chroma for the measurement of turbidity value. According to the usage environment, self-cleaning function can be equipped with. It assures the stability of data and reliability of performance; with the built-in self-diagnosis function, it can make sure the accurate data be delivered; besides, the installation and calibration is quite simple.

Specifications	Details
Size	Diameter 60mm* Length 256mm
Weight	1.65 KG
Main Materials	Main Body:SUS316L (Ordinary Version),Titanium Alloy (Seawater Version) Upper and Lower Cover: PVC; Cable: PVC
Waterproof Rate	IP68/NEMA6P
Measurement Range	0.01-100 NTU 、 0.01—4000 NTU
Indication Resolution	Less than $\pm 2\%$ of the measured value, or ± 0.1 NTU Maximax criterion
Pressure Range	≤ 0.4 Mpa
Flow velocity	≤ 2.5 m/s、 8.2ft/s
Storage Temperature	-15~65°C
Environment Temperature	0~45°C
Calibration	Sample Calibration, Slope Calibration
Cable Length	Standard 10-Meter Cable, Max Length: 100 Meters
Warranty Period	1 Year
High Voltage Baffle	Aviation Connector, Cable Connector
External Dimension:	

Table 1 Specifications of Turbidity Sensor

1.1.2 Turbidity transmitter

The transmitter can be used to display data measured by the sensor, so the user can get the 4-20mA analog output by transmitter's interface configuration and calibration. And it can make relay control, digital communications, and other functions a reality.

The product is widely used in sewage plant, water plant, water station, surface water, farming, industry and other fields. The transmitter diagram is shown as figure 1.

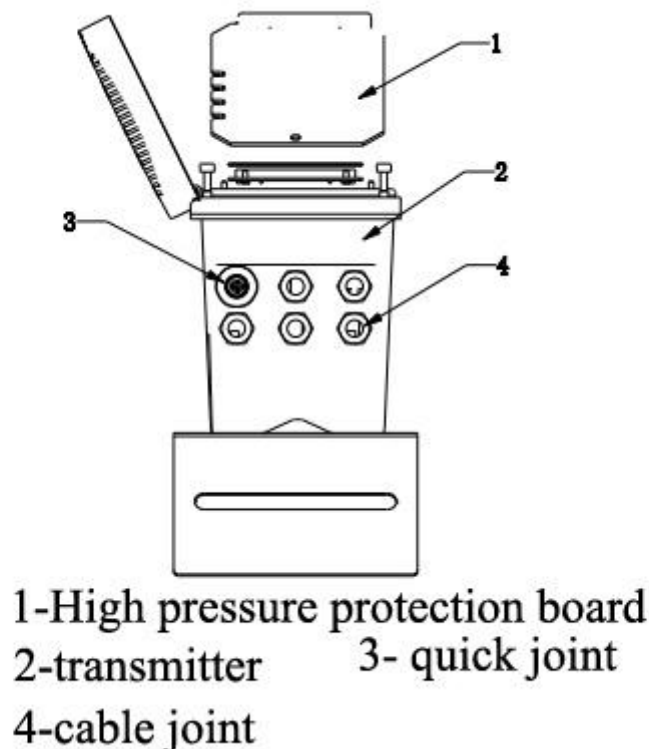

Figure 1 Transmitter

① Relay, output and the signal

The transmitter is equipped with three configurable relay switches and two-way analog output.

② Sensor and the sensor module

The transmitter is a single-parameters one, can contain one sensor.

③ Transmitter shell

Transmitter shell is of IP65 protection class. For outdoor use, it's strongly recommended to take protective measures to prevent environmental damage.

Turbidity Online Analyzer Operation Manual

Specification	Details
Size	145*125*162mm L*W*H
Weight	1.3KG
Material of outside shell	lower casing: Aluminum with powder covering
	cover: PA66+GF25+FR
Waterproof Rate	IP65/NEMA4X
Storage Temperature	-20 to 70℃
Operation Temperature	-15 to 60℃
Power Supply	AC: AC220V, 50HZ, 5W DC: DC24V
Output	three-way analog output 4-20mA, response parameters and corresponding scope can be programmed Note: the maximum load is 500 ohms
Relay	three-way relay can be set up, and response parameters and response values can be programmed
Display Output	128 * 64 dot matrix LCD with LED backlight, which can be operated under the direct sunlight
Digital Communication	MODBUS RS485 communication function, which can transmit real-time measurements
Warranty Period	1 year

Table 2 Transmitter Specification

1.2 Safety Information

Please read this manual completely before opening the package, installing or using. Otherwise it may cause personal injury to the operator, or cause damage to equipment.

Warning labels

Please read all labels and signs on the instrument, and comply with the security label instructions, otherwise it may cause personal injury or equipment damage.

When this symbol appears in the instrument, please refer to the operation or safety information in the reference manual.



While this symbol indicates an electric shock or risk of death from electric shock.

Please read this manual completely. Pay particular attention to some notes or warnings, etc. To ensure that the protective measures provided by the equipment are not destroyed.

Chapter 2 Installation

2.1 Transmitter Installtion

You can install the transmitter in a variety of ways, please refer to the instructions of this manual for installation details.

2.1.1 Installation Components and Size

- ① Figure 2 shows the transmitter installation components.

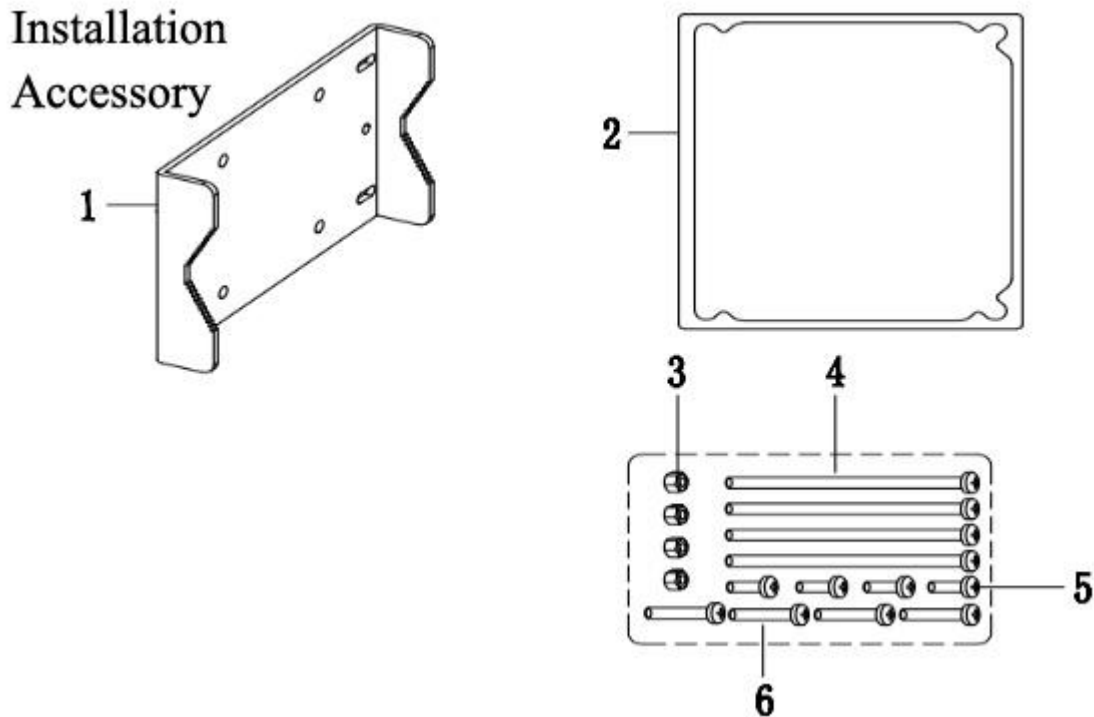

Figure 2 Installation Components

1- mounting plate	2- sealing ring of mounting plate
3- M5 nut	4- M5*100 bolt
5- M5*8 bolt	6- M5*40 bolt

② Figure 3 shows the transmitter installation size.

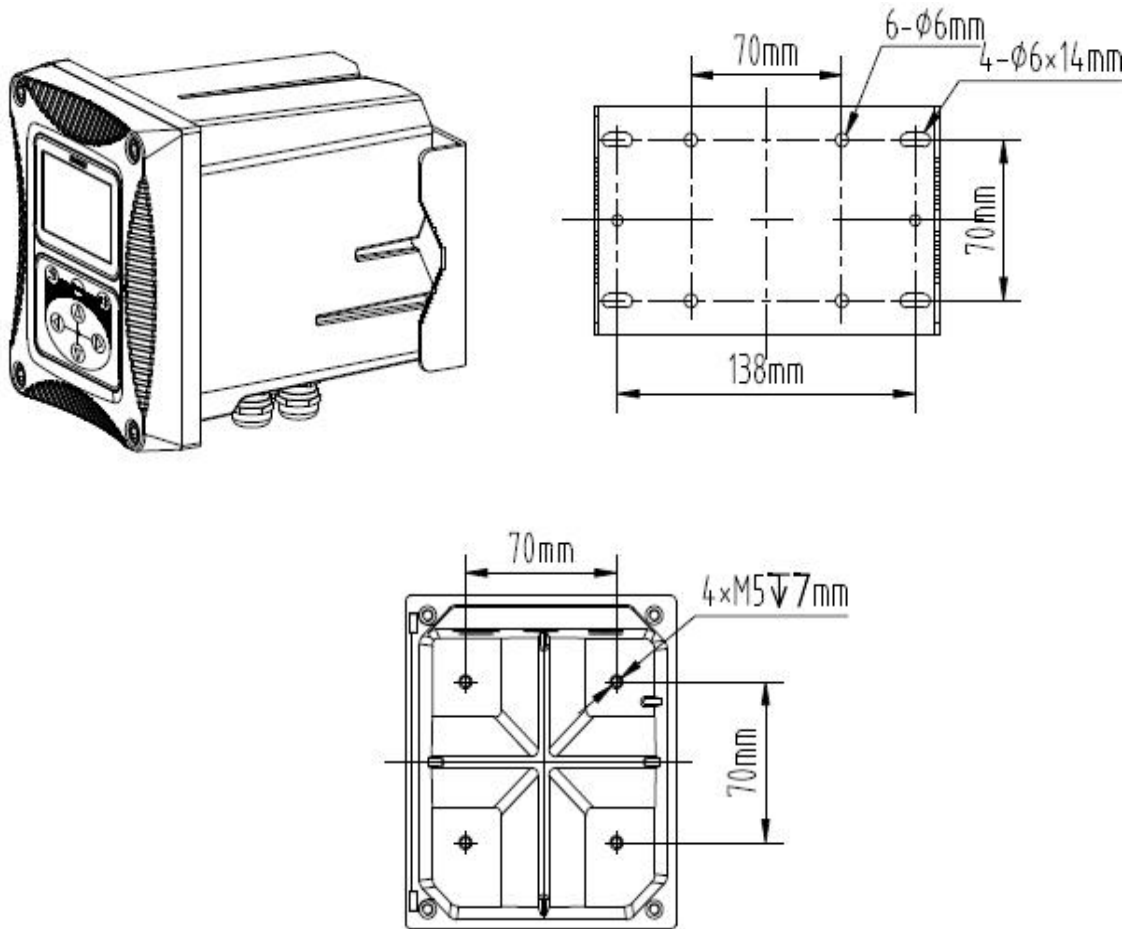

Figure 3 Installation Size

2.1.2 Installation Instructions

a. Pinch Tube Installation Method

Place the transmitter and mounting plate on both sides of the pinch tube, and then use the mounting bolts and nuts to fix them onto the Pinch Tube as shown in Figure 4.

b. Wall-mounted Installation Method

Mount the transmitter with mounting bolts and nuts onto the mounting plate, and then fix the mounting plate on the wall or plate.

c. Panel Installation Method

Firstly, set the transmitter into the panel, and then mount the transmitter with nuts and bolts onto the panel as shown in Figure 5. Bottom view and top view are shown in Figure 6.

In the installation way of clamp, the diameter of clamp is 1 inch to 2.5 inches.

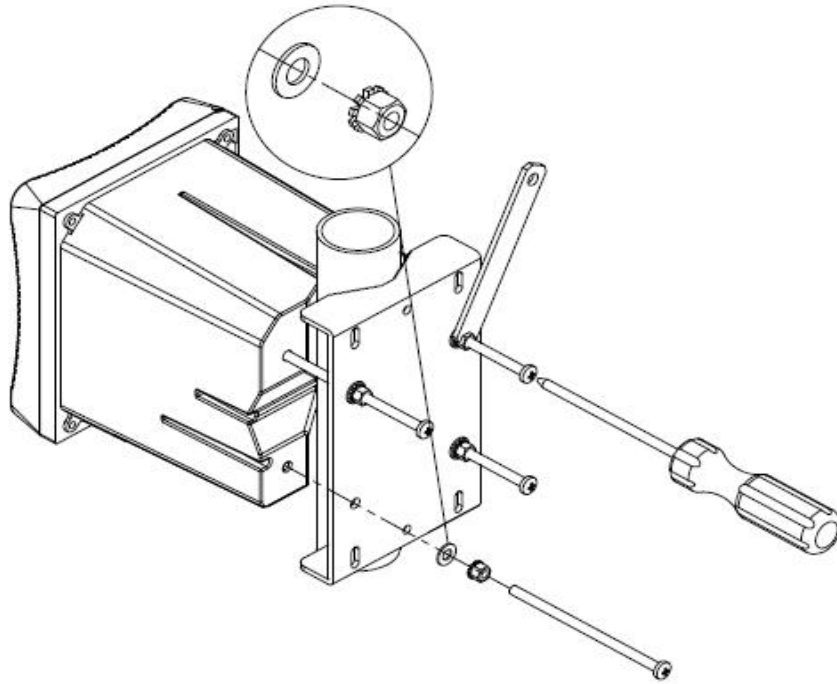

Figure 4 Installation Way of Clamp

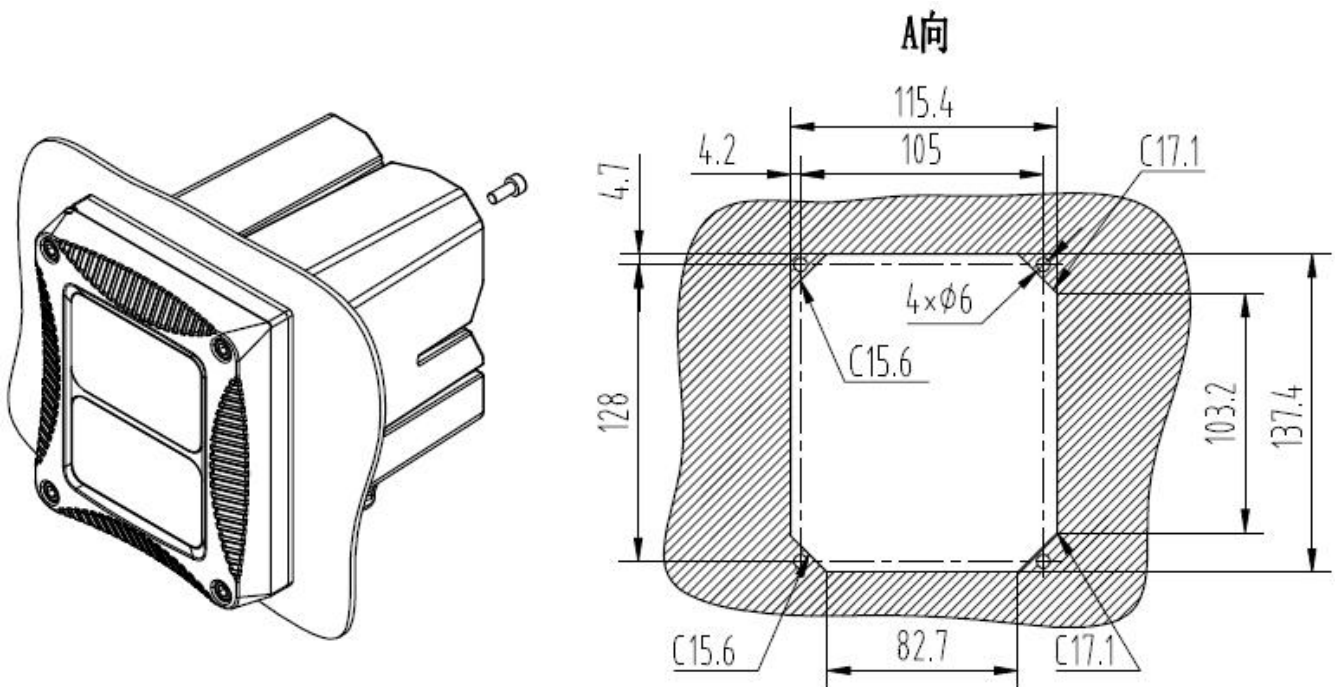

Figure 5 Panel Installation

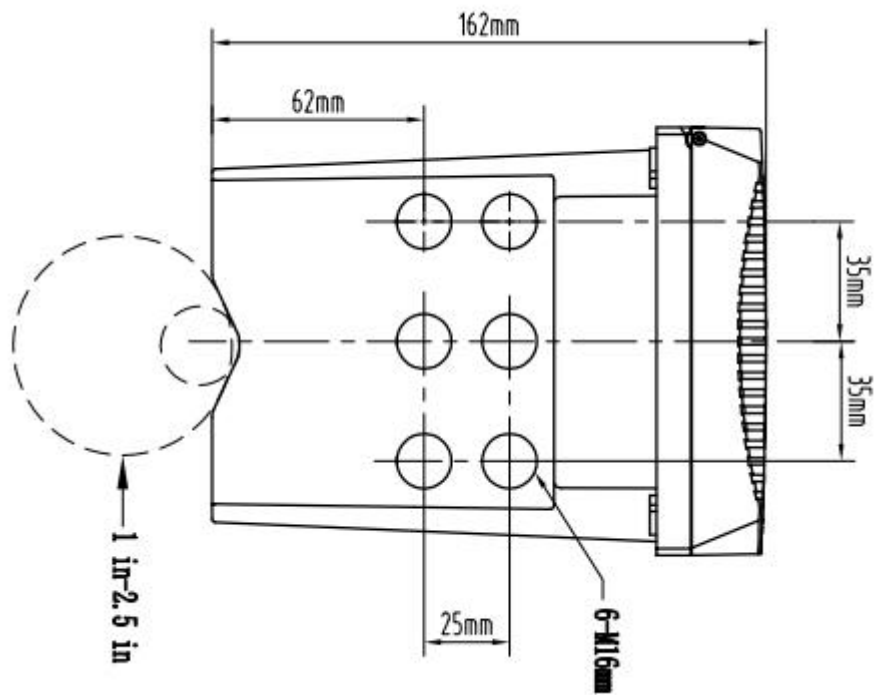
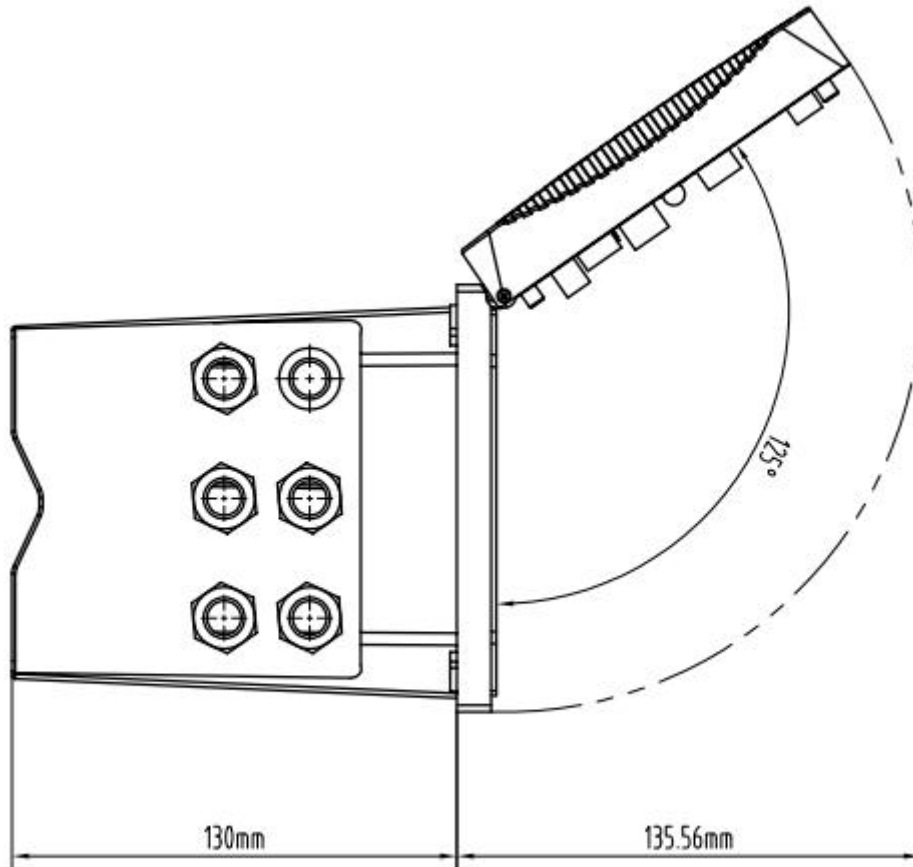

Figure 6 Bottom View, Top View

2.1.3 Wiring Installation

Figure 7 is the preview of internal wiring of the transmitter. Table 3 is the wiring signal of the transmitter.

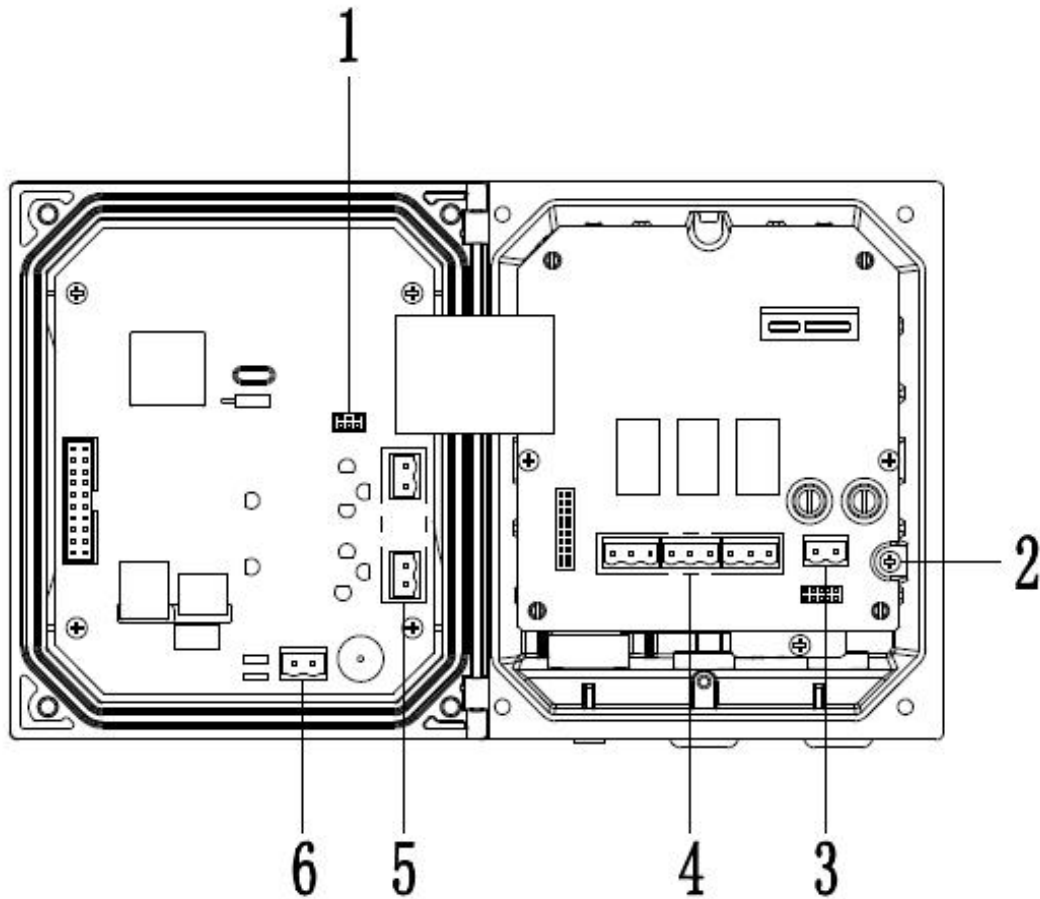

Figure 7 Preview of the Wiring

1- sensor interface	2- grounding
3- power supply interface	4- three-way relay
5- 4-20mA two-way interface	6- 485 communication interface

Table 3 Wiring Signal of the Transmitter.

2.1.4 Power Supply Wiring

The transmitter can use AC220V power supply. Please operate in strict accordance with the wiring instructions.

For the sake of safety and relevant electrical specification, there should be a local disconnect design, and it shall be suitable for all installation types. The connection mode of the power cord is shown as figure 8.

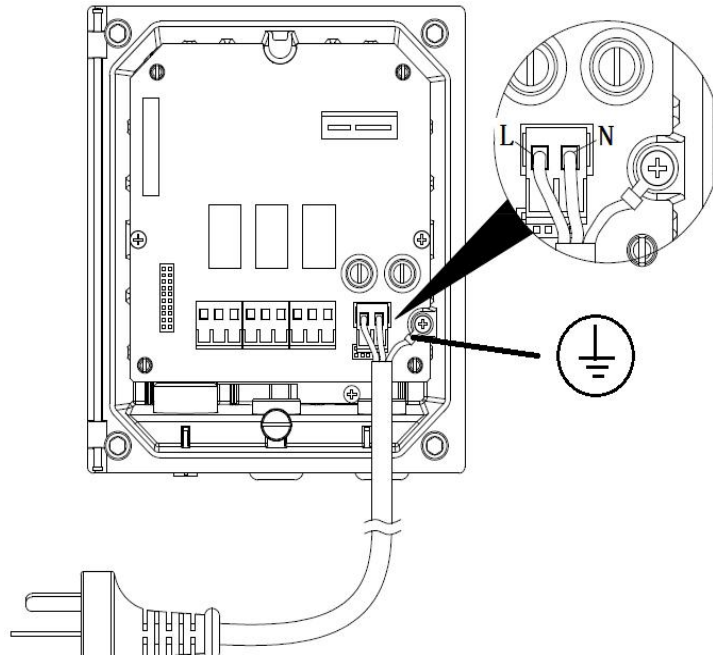

Figure 8 Power Supply Wiring

To ensure the safety in use, please be sure to be grounded.



Note: before any electrical connections, voltage protective layer must be pulled down. After all the connection, and before closing the shell of transmitter, the voltage protective layer should be back the place.

2.1.5 Relay

The transmitter is equipped with three-way relay, and the main measurements or temperature response can be set up. Each relay can be configured individually for timing or alarming, moreover the relay switch and relay response values can also be set. Please be sure to disconnect the power supply, while wiring. The connection mode of the relay is shown as figure 9.

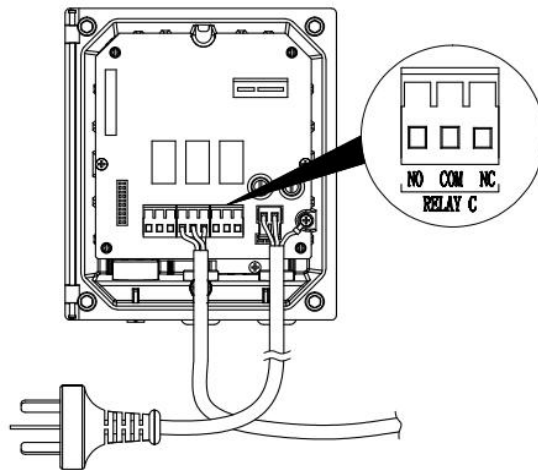

Figure 9 Relay Wiring

2.1.6 Analog Output

Output current should be configured, to use it rationally. The parameters configured includes response parameters and corresponding measured value of 4mA and 20 mA.

2.2 Installation of Sensor

2.2.1 Connection of Sensor

As shown in Figure 10, connect turbidity sensor with the transmitter.



Figure 10 The Diagram of Sensor connection

2.2.2 Installation of Sensors

The specific installation steps are as follows:

- a. Install the 8 (mounting plate) on the railing by the pool with 1 (M8 U-shape clamp) at the sensor mounting position;
- b. Connect 9 (adapter) to 2 (DN40) PVC pipe by glue, pass the sensor cable through Pvc pipe until the sensor screws into 9 (adapter), and do waterproof treatment;
- c. Fix 2 (DN40 tube) onto 8 (mounting plate) by 4 (DN42U-shape clamp).

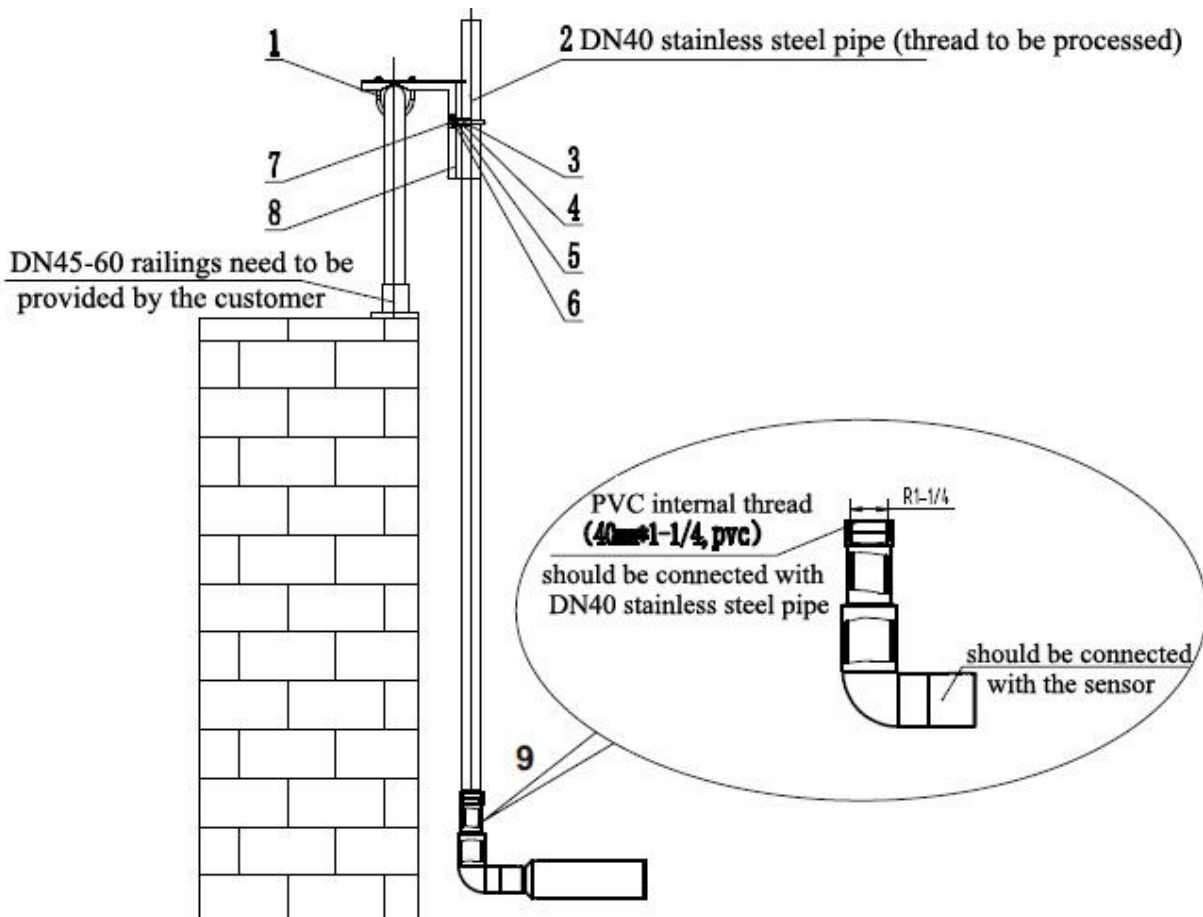

Figure 11 Schematic Diagram on the Installation of Sensor

1-M8U-shape Clamp (DN60)	2- DN40 Pipe
3- Hexagon Socket Screw M6*120	4-DN42U-shape Pipe Clip
5- M8 Gasket (8*16*1)	6- M8 Gasket (8*24*2)
7- M8 Spring Shim	8- Mounting Plate
9-Adaptor(Thread to Straight-through)	

Chapter 3 Product Interface and Operation

3.1 The User Interface

The user interface is shown as figure 12.

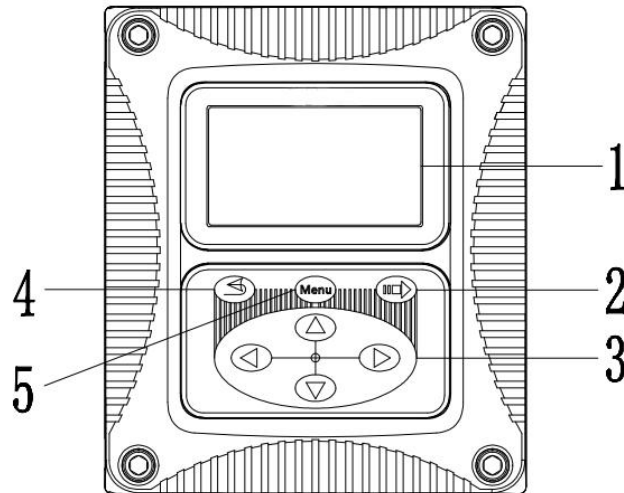

Figure 12 The User Interface

1- screen	2- enter key
3-guide key	4- Esc key
5-menu key	

The user can operate through the panel, setting up and configuring input/output, screen and so on.

No.	Key	Function
2	Enter key	Enter the next menu or accept typed value
3	Guide key	Browse the menu, change the settings, and add or reduce digits
4	Esc key	Return to previous menu
5	Menu key	Go to the main menu

Table 4 Each Key's Function of Transmitter Panel

3.2 The Main Screen

When a sensor is connected to the Transmitter, the screen shows measured data of the sensor, calibration, configuration and settings, time, warnings, errors and so on. The main screen is shown as figure 13.

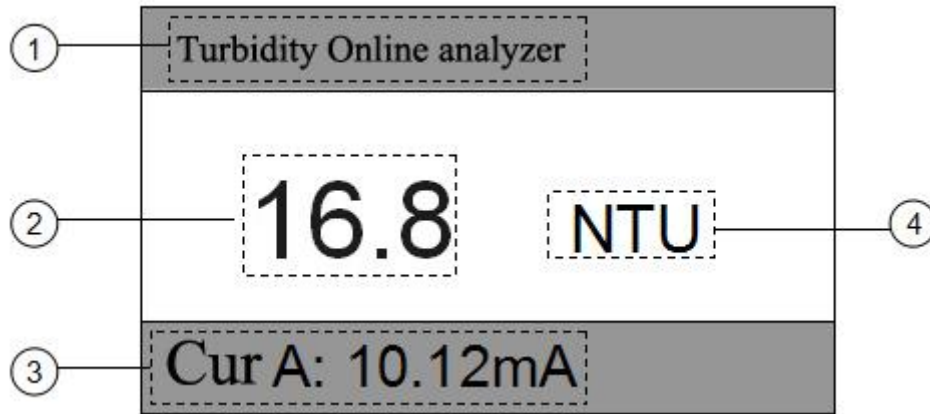

Figure 13 The Main Screen Interface

1- The name of the instrument	2- the measured data of sensor
3-fault display/current loop output/relay/ (main screen switch, right and left)	
4- the unit of measured data	

3.3 Control Set

"Device Info", "CAL OUT" and "SETUP" can be set in "Control Set". And in the "SETUP" we can check and set "Current 1/2", "Relay settings", "485 Address", "Contrast" and "Language".

3.3.1 Device Information

If you want to check the device information, press "up" "down" key to choose the "Device info", then press the "enter" key. You can check the device information after seeing the screen showing "Device info".

3.3.2 Current Output

- 1) Press the menu key, press "up" "down" guide key to select "Control Set" on the interface.
- 2) Then select "CAL OUT", and select the one of the two channels, by adjusting

corresponding AD value of 4mA and 20mA to correct the current.(4 mA corresponds around 800 AD value, 20 mA corresponds around 4000 AD value.)

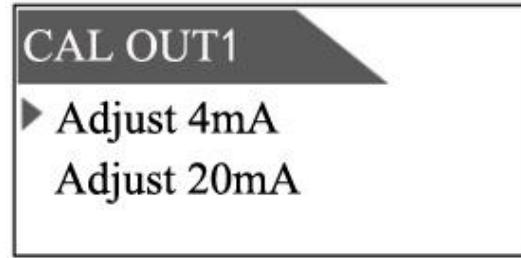
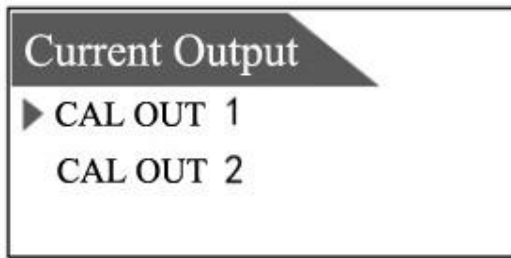

3.3.3 SETUP

3.3.3.1 Setting the current output 1/2

1. press the menu key, then press "up" "down" key to select "Control Set" in the interface;
2. press "up" "down" guide key to select " SETUP " in the "Control Set ";
3. press "up" "down" key to select "Current1/2", then press "enter " key;
4. enter the interface entered is as following;

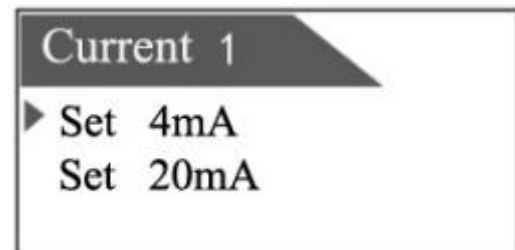
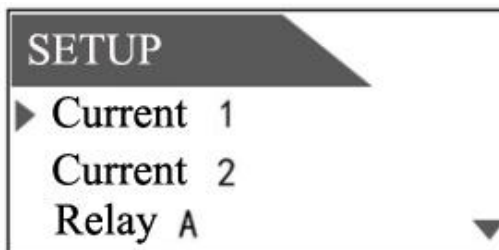

5. then press "up" "down" key to choose set output (4 mA or 20 mA), then enter;
6. pressing "left", "right", "up", "down" key to choose needed value, then enter to complete the set-up.

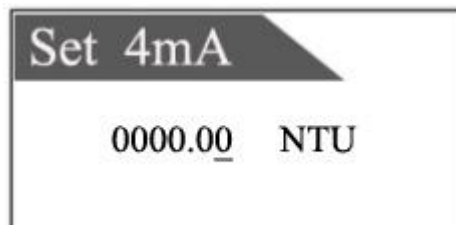

And the program regards 4 mA the lowest, 20 mA the highest in their corresponding value range.

3.3.3.2 RelayA/B/C

1. press the menu key, then press "up" "down" key to select "Control Set" in the interface;
2. press "up" "down" guide key to select "SETUP" in the "Control Set";
3. press "up" "down" key to select "Relay A/B/C", then press "enter" key;

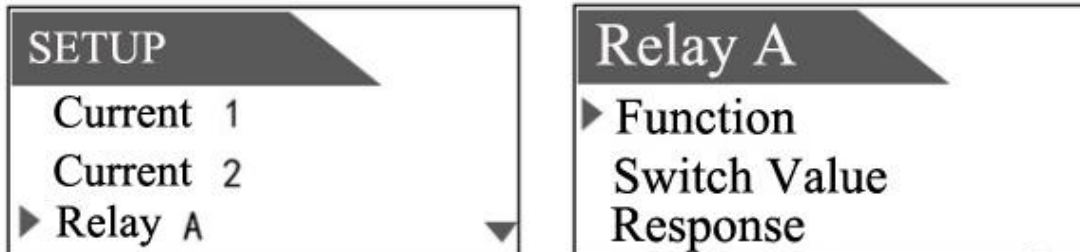

1) To Set Function

Relay can be individually configured for timer or alarm function. Specific steps are as followings: Press the "Function" in the "Relay A/B/C" interface, then select "Warn" or "Time" to enter.

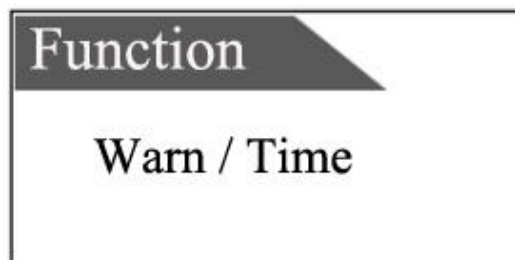

Time:The function of relay's timing is, it works in a specific period of time, which is set as "Keeping", while in the rest of time, it's closed, and the time is a designed period. If you want the relay to work for 10s, closed for 50s, then you can set the "Keeping" as 1min.

Warn:The relay's alarm works when it gets two measured values which are higher or lower than a specific threshold in a continuous interval, assigned by "on time delay", then it will be closed. And when the alarm ends, "the dead zone of threshold" happens: when measured value < high threshold value - high dead zone of threshold, "high threshold alarm" ends; while when measured value > low threshold value + low dead zone of threshold, "low high-threshold alarm" ends.

2) To Set Corresponding Values

The response values have "low alarm", "high alarm", "low deadband", "high deadband", "off time delay" and "on time delay relay" when you choose the "Warn" in "Function". The response values have "Interval" and "Hold time" when you choose the "Time" in "Function".

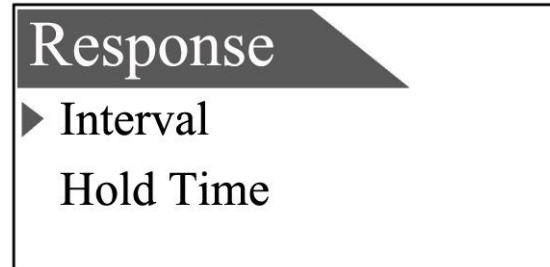
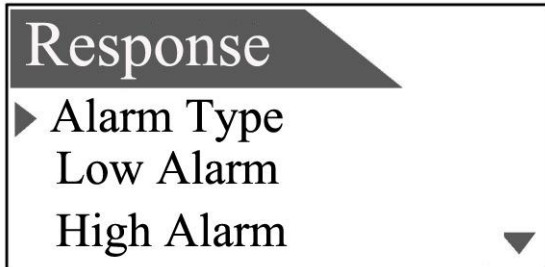

① High Threshold Alarm

When the measured value goes high, the relay will set up corresponding higher limit value. When "alarm type" is set as "high threshold alarm", then the "high threshold value", "high dead zone of threshold", "on time delay" and "off time delay" should be set. The function of "high dead zone of threshold" is to end the alarming: for example, setting the "high threshold value" as 8, "high dead zone of threshold" as 0.2, so when the measured value is less than 7.8, then the alarm ends.

② Low Threshold Alarm

When the measured value lowers down, the relay will set up corresponding lower limit value. When "alarm type" is set as "low threshold alarm", then the "low threshold value", "low dead zone of threshold", "on time delay" and "off time delay" should be set. The function of "low dead zone of threshold" is to end the alarming: for example, setting the "low warning point" as 2, "low high dead zone of threshold" as 0.2, so when the measured value is more than 2.2, then the alarm ends.

③ Off Time Delay Relay

Set a time value, using it as the delay time from relay's closed to starting station.

④ On Time Delay Relay

Set a time value, using it as the delay time from relay's starting to closed station.

3.3.3.3 Communication Setting

A. the transmitter is equipped with MODBUS RS485 communication function, please refer to this manual section 2.1.3 figure 7 to check the communication wiring. The transmitter is with RTU mode of communication, and the default baud rate is 9600, the specific MODBUS RTU table is shown in the following table.

MODBUS-RTU	
Baud Rate	4800/9600/19200/38400
Data Bits	8 bit
Parity Check	no
Stop Bit	1bit

B. the transmitter adopts the MODBUS standard protocol. The specific agreement content is as the following table shows.

Register Name	Register Address	Data Type	Length	Read /Write	Function Code
the value of Sensor	00	float	2	read	04

C. the device address is used as the communication setting, and specific steps are as followings:

- 1, press the menu key, then choose "Control Set" by pressing "up" "down" in the interface;
- 2, press "up" "down" guide key to select "SETUP" in the "Control Set";
- 3, press "up" "down" key in the "SETUP" menu to choose interface "485 address",
- 4, in the "485 Address", press "left" "right" to change "bit" information, and press "up" "down" to change "value" information. 1-254 can be adjustable.

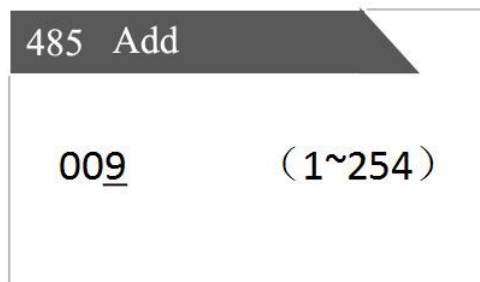

3.3.3.4 Contrast Level

1. press the menu key, press "up" "down" key to choose "Control Set" in the interface;
2. press "up" "down" key to choose "Contrast " in the "Control Set", then press "= >" to enter;
3. press "up" "down" key to adjust contrast , and the range is 0-9. Setting interface is as shown.

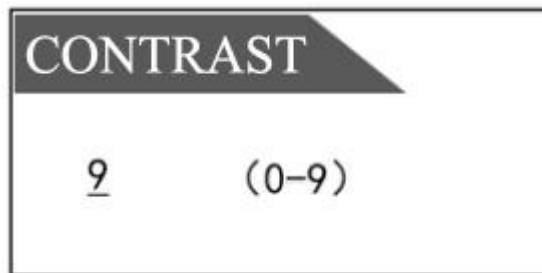

3.3.3.5 Language Settings

1. press the menu key, press "up" "down" key to choose "Control Set" in the interface;
2. press "up" "down" guide key to choose "Language" in the "Control Set";
3. press "left" "right" to choose the needed language in the "Language", then press "= >" to enter. There are two language options, Chinese and English. Setting interface is as shown.

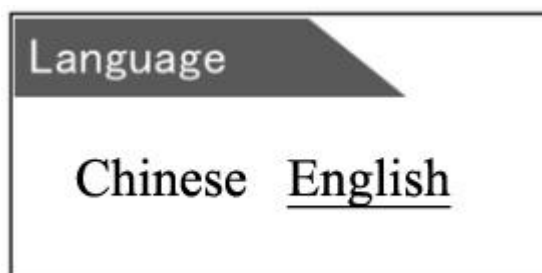

3.4 Parameters Setting

The sensor can be configured with options such as divisor, offset value, units, response time, wiper, current data and default values. Use the configuration menu to set various parameters for the sensor. **The procedure is as follows:**

1. Select "Menu", Press "Up" ,"Down" key to select "Probe Set".
2. Select the desired adjustment parameters in the parameter settings interface, after entering the appropriate setting interface, use the guide keys to set the required value, and finally press the "Enter" key to complete the configuration. The options that can be configured and viewed are shown in the following table.

Options for Sensor Configurations

Options	Description
divisor	The current default correction factor is 1.
Deviation (Offset Value)	The deviation value defaults to 0.00mg/l
Unit	The unit of measurement can be set to FTU, NTU,EBC
Response Time	Set the response time of the signal, the default is 60 seconds
Measured Value	Real-time measured value of the sensor
Wiper	Manually clean, set cleaning interval.
Reset Default	Restore the sensor default settings

Chapter 4 Calibration of Sensor

The turbidity sensor has been calibrated at the factory, and can be calibrated according to the following procedures. It requires the use of turbidity standard solution to calibrate turbidity, and **the specific steps are as follows:**

If there is a large deviation between the measured value and the standard value, the slope of calibration curve needs factor correction.

1. Connect the sensor to the transmitter;
2. Set the relevant parameters and wipe the sensor;
3. Slowly immerse the sensor into the turbidity standard solution;
4. Wait for the value to be stable and record the stable value;
5. Calculate the correction factor. The correction factor equals to the standard solution value divided by the value measured in the fourth step. (Factor = standard solution value / stable value)
6. Select “Menu”> “Probe Settings”> “Divisor”, enter the calculated correction value in the “Divisor”, and press “Enter” to complete the calibration.

Chapter 5 Maintenance

5.1 Maintenance of Transmitter

The maintenance of the transmitter is mainly to clean the transmitter, check the appearance and cable damage. The transmitter is an electronic device, and improper use of the environment may cause damage to the transmitter.

- 1.The environment above 60 °C in where the instrument is used will cause damage to the instrument.
- 2.False power or power fluctuations can cause damage to the instrument.
- 3.A collision or a drop can cause the damage of instrument.
- 4.Moisture, corrosion and air pollution can cause damage to the instrument.

Transmitter Cleaning: Ensure that the transmitter cover is closed tight and use a clean, wet cloth to wipe the outside of the transmitter.

Transmitter Inspection: regularly check the instrument working status to see if it is normal; regularly check the panel, terminals, switches, buttons, etc. If they are dirty, clean and sweep them.



Warning: Before maintenance, disconnect the power of the transmitter to ensure personal safety.

5.2 Maintenance of Sensor

In order to obtain the best measurement results, it is very necessary to maintain the sensor regularly. Maintenance mainly includes cleaning, inspecting damage of the sensor, and periodic calibration. You can also view the sensor's status during maintenance and inspection.

5.2.1 Status of Sensor

Follow the steps "Menu"> "Detection "> "Status" to view the main status of the sensor, data, connection, humidity, maintenance cycle,and Sealing Ring

When each state is normal, the display of each parameter is as follows:

Turbidity Online Analyzer Operation Manual

Parameters	Status	Parameters	Status
Connection	OK	Maintenance Circle	90D
Data	OK	Sealing Ring	365D
Humidity	OK		

When the sensor status is not normal or the alarm is displayed, it might be the following circumstances:

1. Loss of Sensor

Parameters	Status	Parameters	Status
Connection	LOSE	Maintenance Circle	90D
Data		Sealing Ring	365D
Humidity			

2. Main Value Outrange

Parameters	Status	Parameters	Status
Connection	OK	Maintenance Circle	90D
Data	WARN	Sealing Ring	365D
Humidity			

3. Humidity Alarm

Parameters	Status	Parameters	Status
Connection	OK	Maintenance Circle	90D
Data	OK	Sealing Ring	365D
Humidity	WARN		

4. Maintenance Circle

Parameters	Status	Parameters	Status
Connection	OK	Maintenance Circle	0D
Data	OK	Sealing Ring	0D
Humidity	OK		

5.2.2 Sensor Cleaning

Both the two lenses on the sensor need to be cleaned and maintained regularly to ensure the accuracy of the measurement on the basis of actual use. Wash with clean water, then wipe with a cleanser and rag to remove stubborn stains.

5.3 Inspection on the Damage of Sensor

Check the appearance of the sensor to see whether there is damage, if it's damaged, please contact to the after-sales service center in time for replacement to prevent malfunction of sensor caused by water due to the damage.

5.4 Sensor Blade Replacement

It is recommended that the blade of the sensor should be replaced quarterly with a new rubber one, the specific steps are as follows:

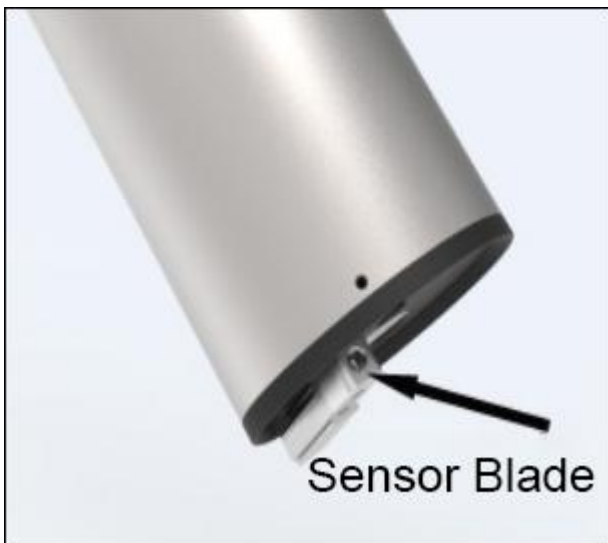

- 1.The position of the blade is shown on the left picture;
- 2.Remove the screws on the blade with the corresponding screwdriver;
- 3.Remove the blade, take out the rubber sheet inside, and replace it with a new one;
- 4.Finally put the blade back, and fasten the screw and blade with a screwdriver.

5.5 Fuse Replacement

If the fuse is burnt out, it indicates there exists a problem during installation or use. Be sure the problem is solved before replacing the new fuse. The specific steps are as follows:

1. Disconnect the transmitter from the power supply.
2. Loosen the four screws on the transmitter cover and then open it.
3. Remove the high voltage shield, unscrew the screws fixing the power supply board, and take out the power supply board.
4. Remove the fuse, install a similar one, and tighten it.
5. Install the power board back, and the high voltage shield too.
6. Close the cover and tighten the screws on it.
7. Re-connect to the power supply.

CAUTION: When replace the fuse, be sure to keep the transmitter out of power and prevent the risk of electric shock.

Chapter 6 Errors and Warning

If an error or warning occurs, the reading on the measurement screen will flash and "Fault" will be displayed at the bottom. The following are common mistakes and warnings:

1) Loss of Sensor

When the sensor is not connected to the transmitter or the connection between the probe and the transmitter is bad, there will be an alarm about the loss of probe, the screen will continue to flash and display "LOST", and it will display "Fault" word in its next line. When it happens, follow the steps below to scan the probe.

1. Press "Menu" to enter the main menu.

2. Press the navigation keys "Up"/ "Down" to select "Detection ", and Press "Confirm" to enter Setting.

3. Select the "Scan Probe" interface , and a prompt will ask you whether to continue. Select "Confirm" to complete the probe scan. The process is shown in the figure. If it's successful, it will display "Scan Completed! Success"; if it's failed, it will display "Scan Completed! Failed".

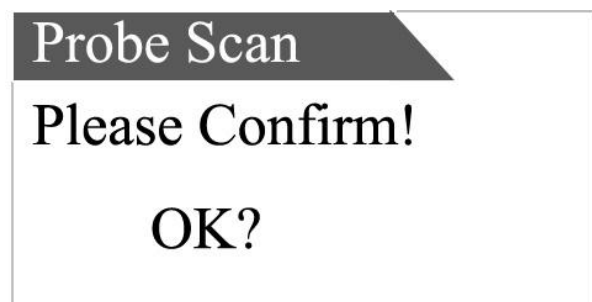
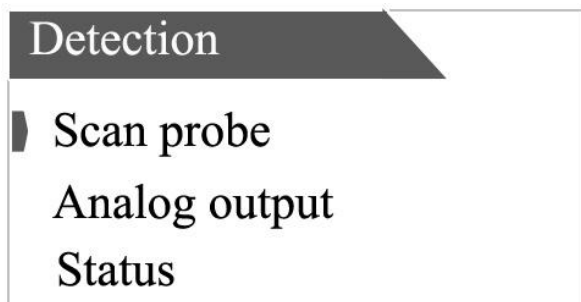

2) Humidity Alarm

When a humidity alarm appears, it indicates that the inside of the sensor gets water, the reading on the measuring screen will flash and the word "Fault" will be displayed on the next line of the number. If there is a humidity alarm, it means water gets into the probe, please promptly send the probe to the after-sales department for maintenance.

3) Measured Value Outrange

When the measured value exceeds the range, the screen will appear flashing "++ • ++" words, in its next line will display "Fault" word.

4) ERR3 Alarm

When the ERR3 alarm occurs, it indicates the current loop is out of range, at this time, the reading on the screen will flash continuously and "ERR3" will be displayed below the reading. In case of such warning, please contact technical support or after-sales service department.

Chapter 7 Problems and Solutions

Common Problems and Solutions:

Malfunction	Solutions
Overweight Alarm	Reboot the transmitter to check if it is still overweight and contact technical support if it still appears.
Loss of Sensor	Check if the cable is plugged in and reconnect the cable; restart the transmitter or select the scan probe in the "Inspection / Maintenance Settings" and rescan the probe.
Humidity Alarm	Return it to after-sales service department for maintenance.
Maintenance Circle Alarm	contact our after-sales service or technical support department.

Note: In case of other unsolvable problems, please contact our after-sales service or technical support department.