

Metal Tube Rotameter



Supmea

Headquarters

5th floor, Building 4, Singapore Hangzhou Science Technology Park, No. 6 street, Hangzhou Economic Development Area, Hangzhou 310018, China

Singapore

2 Venture Drive #11-30 Vision Exchange Singapore

✉ info@supmea.com

🌐 www.supmea.com

Supmea Automation Co.,Ltd.

Foreword

- Thank you for purchasing our products.
- This manual is an instruction manual for the product's various functions, wiring methods, setup methods, operation methods, troubleshooting methods, etc.
- Please read this manual carefully before operation and use this product correctly to avoid unnecessary losses due to incorrect operation.
- After you have finished reading, please keep it in an accessible place for your reference during operation.

Note

- The contents of this manual are subject to change without notice due to feature upgrades or other reasons.
- We strive to ensure the accuracy of the information in this manual. If you find any errors, please contact us.
- The contents of this manual are strictly prohibited from being reproduced or copied.
- This product is prohibited from application in explosion-proof environments.

Version

U-LZ-SUP-EN1

Contents

1 Overview	1
2 Measuring Principle	2
3 Features	4
4 Technical Parameters	5
5 Types and Dimensions	7
5.1 Types	7
5.2 Flange Dimensions	16
5.3 Magnetic Filter	18
6 Indicators and Limit Alarm Devices	19
6.1 Indicator Selection	19
6.2 Alarm Device Selection	20
7 Diameter Calculation and Flow Rate	23
7.1 Liquid Flow Calculation	23
7.2 Calculation of Gas Flow Rate	24
7.3 Float Density Table for Various Materials	26
7.4 Flow Tables	27
8 Installation Method and Precautions	30
8.1 Installation Precautions	30
8.2 Maintenance	32
9 Electrical Connection	33
10 The Indicator Usage	34
10.1 Button Functions	34
10.2 Accessing Parameter Groups	34
10.3 Modifying Parameters	34
10.4 The Parameter Groups And Their Passwords	35
10.5 Example: 4mA Current Correction	37
11 Technical Specification	38

1 Overview

The metal tube rotameter is a type of variable area flow measurement instrument commonly used in industrial automation process control. They are characterized by their small size, wide detection range, and easy operation. They can be used to measure the flow rate of liquids, gases, and steam, and are particularly suitable for measuring low flow rates and small flow volumes.

For many years, metal tube rotameters have been widely used in industries such as petrochemicals, steel, power, metallurgy, light industry, food, pharmaceuticals, and water treatment due to their excellent performance, reliability, and good performance-price ratio.

This manual is intended for technical professionals and applies to the design and selection of metal tube rotameters. It can also serve as a reference manual for end users. It introduces the working principle, functional characteristics, technical parameters, instrument types and appearance, flow calculation wiring methods, installation, and maintenance of this series of metal tube rotameters.

This manual is only for the design, selection, and operation of this metal tube rotameters. The manufacturer reserves the right to make changes to certain technical parameters without prior notice.

2 Measuring Principle

This series of metal tube rotameters mainly consists of two parts: a sensor and an indicator. The sensor mainly consists of a connecting flange, a measuring cone tube, a float, and upper and lower guides; the indicator mainly consists of a housing, a magnetic drive system, a dial, and an electrical remote transmission system.

Inside a vertical conical measuring tube, there is a movable measuring component — a float (Figure 1)—that measures the hydromagnetic body of the conical tube. When fluid flows upward through the conical tube, the float is subjected to the force of the fluid and moves upward along the conical tube. When the fluid flow rate increases, the displacement of the float increases; conversely, when the fluid flow rate decreases, the displacement of the float decreases. That is to say, the magnitude of the fluid flow rate determines the position of the float in the measuring tube, and thus determines the size of the annular area between the float and the conical tube.

When the fluid flow rate is kept at a constant flow rate Q , the float is also in a state of dynamic equilibrium, remaining at a position h in the conical tube. At this time, the annular area between the float and the conical tube remains constant. The float is subjected to three forces: the weight of the float G , the buoyancy force F , and the force P exerted by the fluid. These three forces are in equilibrium. Based on Bernoulli's equation, the principle of force balance, and the law of fluid continuity in fluid dynamics, the instantaneous flow rate of the fluid flowing through the annular area can be calculated. Therefore, the metal tube float rotameter uses the principle of variable area to measure flow rate.

Inside the float, a high-performance permanent magnet is embedded, creating a uniform and stable magnetic field around the float when it is in equilibrium. A magnetic sensor is installed outside the tapered tube, allowing the linear displacement of the float inside the tube to be transmitted to the indicator non-contactly. After detection and processing, the signal is displayed on the indicator dial or output as a standard 4~20mA current signal.

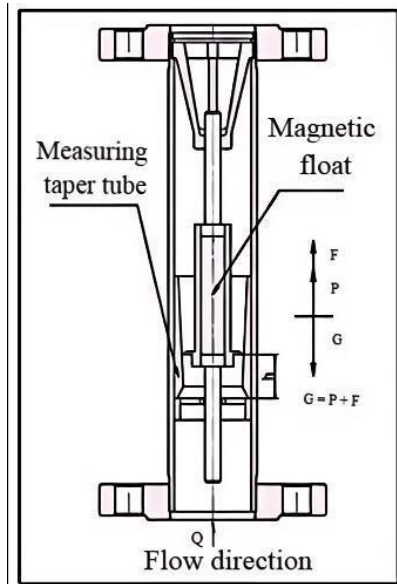

Fig.1

3 Features

- ◆ Suitable for measuring the flow rate of small-diameter and low-velocity media.
- ◆ Low requirement for straight-run installation.
- ◆ Dual-line LCD screen with backlights displays instantaneous/cumulative flow rate simultaneously.
- ◆ All-metal structure, suitable for high temperature, high pressure, and highly corrosive media.
- ◆ Features data recovery, data backup, and power loss protection.
- ◆ Reliable operation, low maintenance, and long service life.
- ◆ A wider range ratio of 10:1.
- ◆ The indicator has a keyboard, making operation and settings convenient.
- ◆ Non-contact magnetic coupling transmission.
- ◆ Selectable DC, AC, or battery power supply.
- ◆ Two-wire systems allowing for upper and lower limit relay alarm.

4 Technical Parameters

Parameters	Specification
Diameters	DN15, DN25, DN50, DN80, DN100, DN150 (For other diameters, please consult with the manufacturer)
Flow Range	- Liquid: 1.0~150000 L/h (See the flow rate table for details on the flow rate range) - Gas: 0.05~3000 m ³ /h
Range Ratio	10:1, 20:1 (Special)
Accuracy	Level 1.5, Level 1.0 (Special)
Pressure Level	- DN15, DN25, DN50: 4.0MPa (Maximum 20MPa) - DN80, DN100, DN150: 1.6MPa (Maximum: DN80: 10MPa; DN100: 6.4MPa; DN150: 4.0MPa)
Medium Temperature	Standard: -30°C to +120°C; High temperature: 120°C to 350°C (PTFE lining must not exceed 80°C)
Power Supply	24VDC (12-36VDC), lithium battery powered, 220VAC
Output Signal	- Two-wire system: 4~20mA DC, 4~20mA DC + HART protocol - Three-wire system: MODBUS (RTU mode); cumulative pulse (24V, 50% duty cycle) - Optional relay alarm, contact capacity: 250V AC 3A
Output Load	5009 (when powered by 24V)
Ambient Temperature	- Local type: -40~120°C - Remote transmission type: -30°C~60°C
Storage Conditions	- Temperature: -40°C to 85°C - Humidity: ≤ 85%

4 Technical Parameters

Parameters	Specification
Connection Method	<ul style="list-style-type: none"> - Standard type: Flange standard GB/T9119-2000, user-specified options available - Food type: Clamp connection method - Special type: Designed according to user requirements
Cable Interface	M20x1.5, 1/2NPT
Enclosure Protection	IP65
Medium Viscosity	<ul style="list-style-type: none"> - DN15: $\eta < 5\text{mPa}\cdot\text{s}$ - DN25: $\eta < 250\text{mPa}\cdot\text{s}$ - DN50 ~ DN150: $\eta < 300\text{mPa}\cdot\text{s}$
Measuring Tube Material	<ul style="list-style-type: none"> -R: 304 (Equivalent to 0Cr18Ni9) -Ro: 316Ti (Equivalent to 0Cr18Ni12Mo2Ti)
Float Material	<ul style="list-style-type: none"> - RL: 316L, 00Cr17Ni4Mo2 - H: Hastelloy B, Hastelloy C - Ti: Titanium, titanium alloy - Rp: PTFE Lining (Polytetrafluoroethylene)
Hygienic Surface Finish	< 0.8Ra (Ra, arithmetic mean deviation of the profile; applicable to hygienic-grade rotameter components in contact with medium)

5 Types and Dimensions

This series of metal tube rotameters consists of a measuring tube (sensor) and an indicator (electronic converter). By selecting different types of measuring tubes and indicators, various types of complete units can be assembled to meet on-site requirements. The shapes and dimensions of various types of rotameters, connection flange standards, and installation dimensions of magnetic filters are described below.

5.1 Types

Based on the flow inlet and outlet directions, this rotameter has 5 types. Each type is further available in standard, high-temperature, and jacketed versions. The details are described below.

5.1.1. Vertical

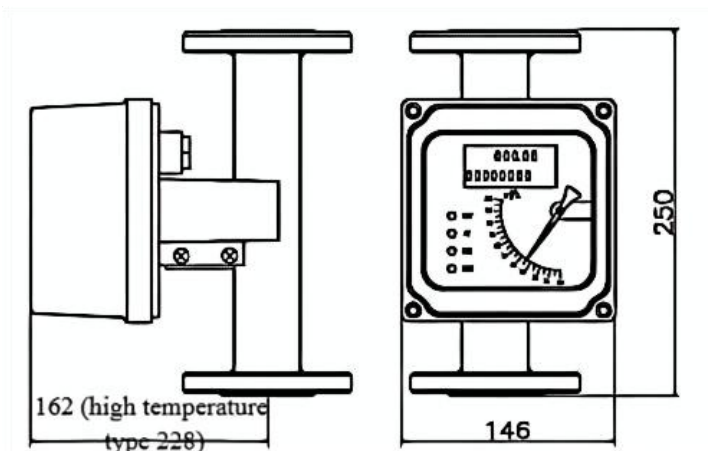

Fig.2 Standard M4 indicator

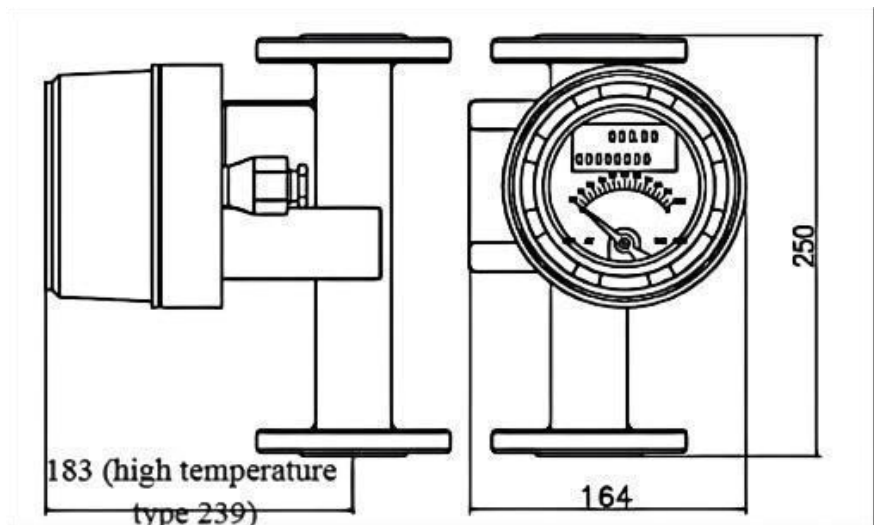

Fig.3 Standard M5 indicator

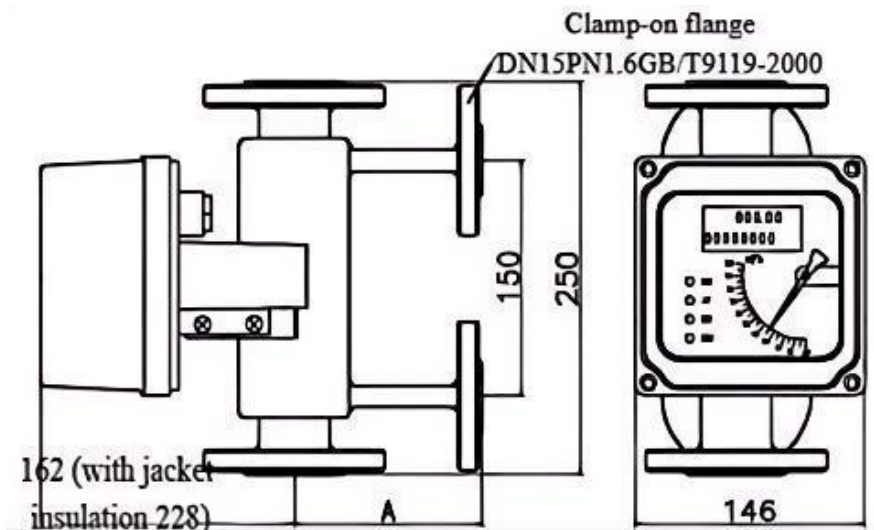

Fig.4 Cooling jacket type M4 indicator

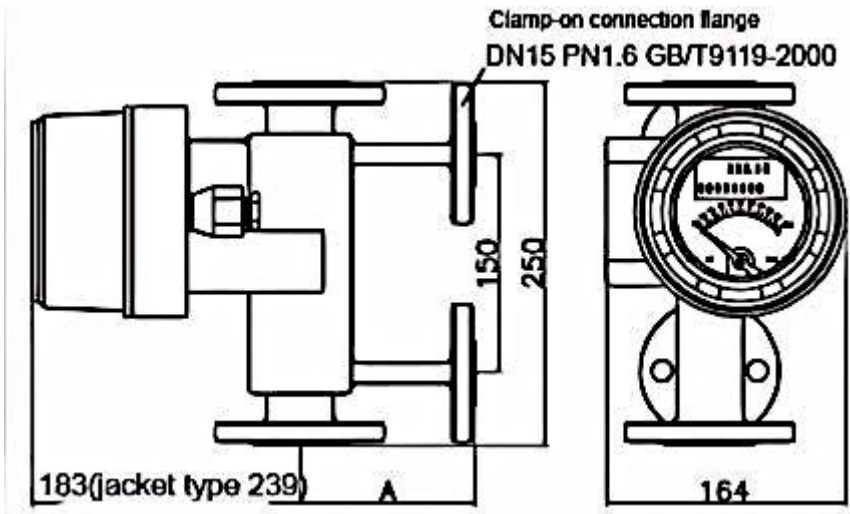

Fig.5 Cooling jacket type M5 indicator

Table 1

Diameter	DN15	DN25	DN50	DN80	DN100	DN150	DN200
A	100	120	135	150	160	180	200
Standard weight (kg)	5.0	6.5	10	16	17	35	50
Jacket type weight kg	7.5	9.5	13	19	20	40	55

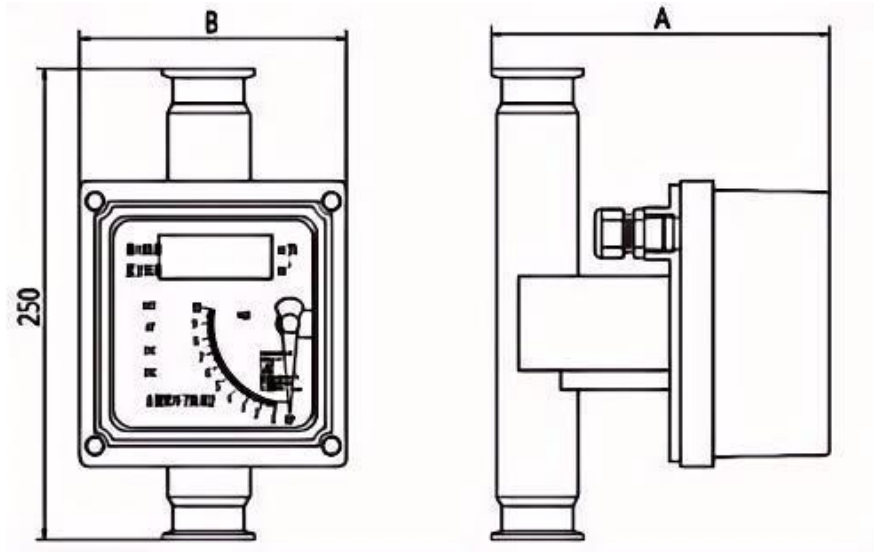

Fig.6 Sanitary type with M4 indicator

Table 2

	ϕ 10	ϕ 19	ϕ 25	ϕ 32	ϕ 38	ϕ 51	ϕ 63	ϕ 76	ϕ 89	ϕ 108	ϕ 114	ϕ 133	ϕ 140	ϕ 159
A	200	200	200	200	200	210	210	220	230	240	250	260	270	280
B	150	150	150	150	150	155	160	170	175	185	190	200	210	220

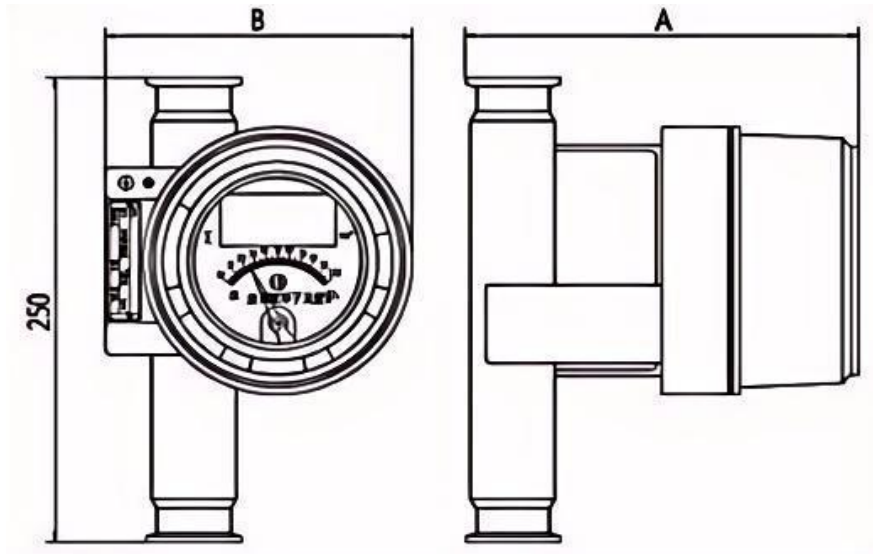

Fig.7 Sanitary type with M5 indicator

Table 3

	ϕ 10	ϕ 19	ϕ 25	ϕ 32	ϕ 38	ϕ 51	ϕ 63	ϕ 76	ϕ 89	ϕ 108	ϕ 114	ϕ 133	ϕ 140	ϕ 159
A	210	210	210	210	210	220	220	230	240	250	260	270	280	290
B	165	165	165	165	165	170	180	190	195	205	220	235	245	270

5.1.2. Horizontal

For horizontally installed rotameters, a T-type structure should be selected when the diameter is less than DN50 (DN50 included), and a spring structure can be selected when the diameter is greater than DN25.

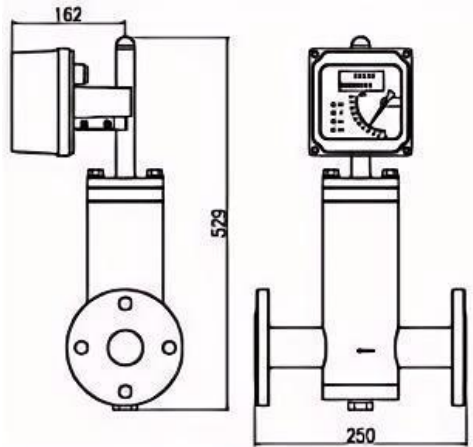

Fig.8 T-shaped structure M4 indicator

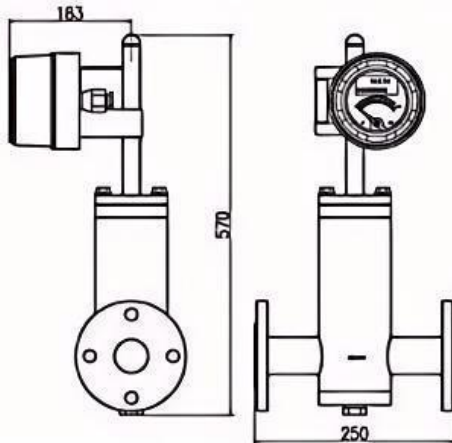

Fig.9 T-shaped structure M5 indicator

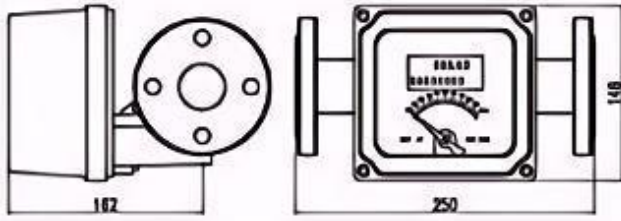

Fig.10 Spring-loaded M4 indicator

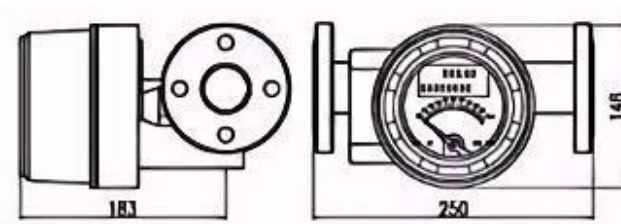

Fig.11 Spring-loaded M5 indicator

Table 4

Diameter	DN15	DN25	DN50	DN80	DN100	DN150	DN200
T-shaped weight (kg)	6	10	20				
Spring structure weight (kg)				16	17	35	50

5.1.3. Bottom-Inlet, Side-Outlet Type

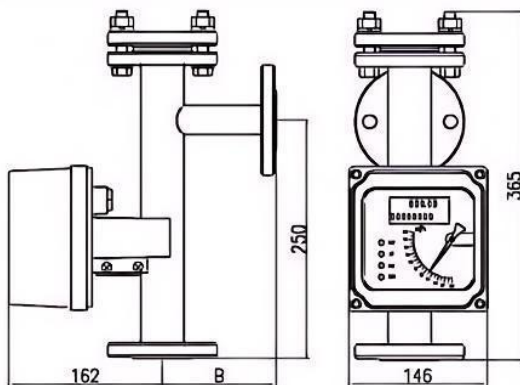

Fig.12 Standard M4 indicator

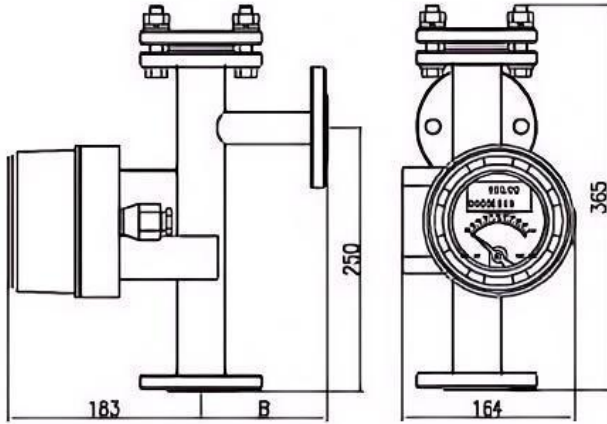

Fig.13 Standard M5 indicator

Table 5

Diameter	DN15	DN25	DN50	DN80	DN100	DN150	DN200
B	100	120	135	150	160	180	200
weight (kg)	6	7	14	24	28	52	60

5.1.4. Side-Inlet, Side-Outlet Type

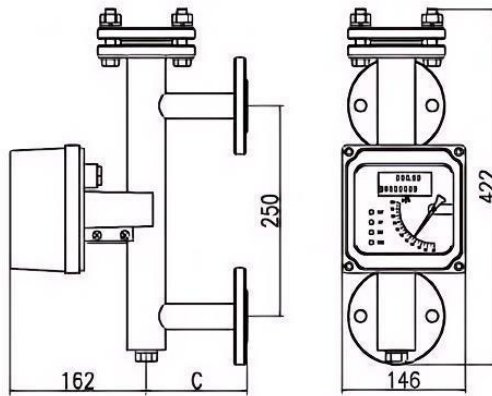

Fig.14 Standard M4 indicator

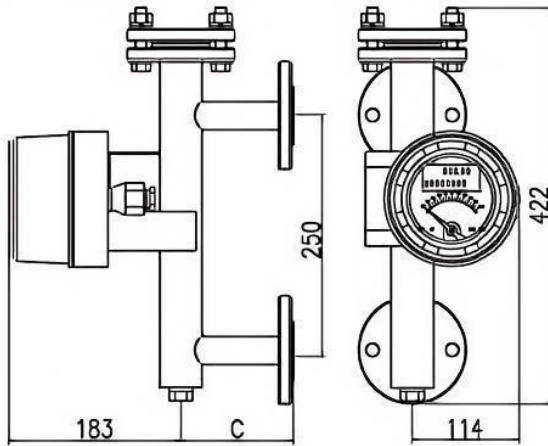

Fig.15 Standard M5 indicator

Table 6

Diameter	DN15	DN25	D N50	DN80	D N100	DN150	DN200
C	100	120	135	150	160	180	200
weight (kg)	5.5	6.5	13	22	26	50	57

5.1.5. Side-Inlet, Top-Outlet Type

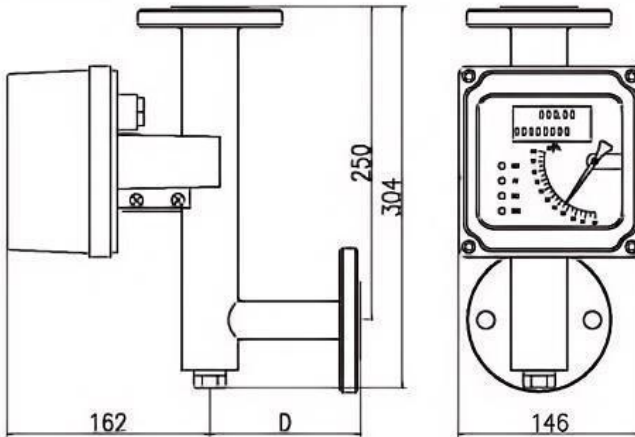

Fig.16 Standard M4 indicator

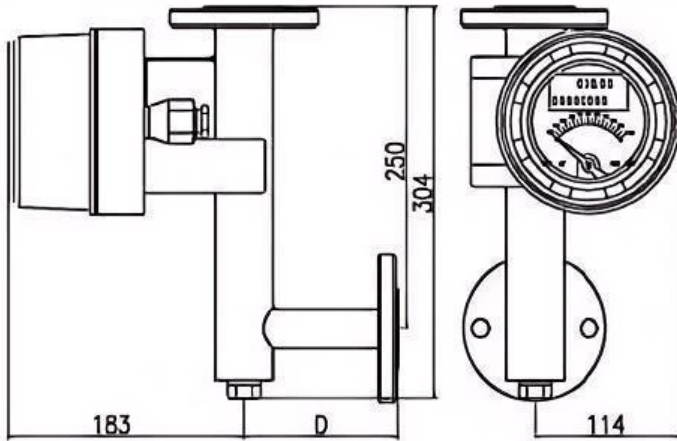

Fig.17 Standard M5 indicator

Table 7

Diameter	DN15	DN25	DN50	DN80	DN100	DN150	DN200
D	100	120	135	150	160	180	200
weight (kg)	5.5	6.5	10.5	16	17	36	52

5.2 Flange Dimensions

The standard type adopts the GB/T9119-2000 flange standard, as shown in Figure 18, and the specific dimensions are shown in Table 8; other flange standards can be supplied according to the user's requirements.

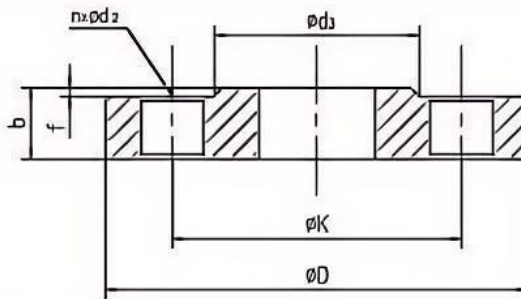

Fig.18 Flange dimensions

Table 8 Chinese National Standard Flanges (GB/T9119-2000)

DN/PN	D	K	d ₃	b	f	n	
15/4.0	95	65	46	14	2	4	14
25/4.0	115	85	65	16	2	4	14
50/4.0	165	125	99	20	2	4	18
80/1.6	200	160	132	20	2	8	18
100/1.6	220	180	156	22	2	8	18
125/1.6	250	210	184	22	2	8	18
150/1.6	285	240	211	24	2	8	22

Table 9 American National Standard Flange (ANSI B 16.5) (1501b)

DN	D	K	d ₃	b	f	n	^2
1/2"	88.9	60.5	35.1	11.2	1.6	4	15.7
r	108.0	79.2	50.8	14.2	1.6	4	15.7
2"	152.4	120.7	91.9	19.1	1.6	4	19.1
3"	190.5	152.4	127.0	23.9	1.6	4	19.1
4"	228.6	190.5	157.2	23.9	1.6	8	19.1
5"	254.0	215.9	185.7	23.9	1.6	8	22.4
6"	279.4	241.3	215.9	25.4	1.6	8	22.4

Table 10 German National Standard Flange (DIN) (2501)

DN/PN	D	K	d ₃	b	f	n	<^2
15/4.0	95	65	46	16	2	4	14
25/4.0	115	85	68	18	2	4	14
50/4.0	165	125	102	20	3	4	18
80/1.6	200	160	138	20	3	8	18
100/1.6	220	180	162	20	3	8	18
125/1.6	250	210	188	22	3	8	18
150/1.6	285	240	218	22	3	8	22

Table 11 The DIN2501 flange standard is essentially equivalent to the following standards; it can be used interchangeably.

Number	Title	Pressure rating PN MPa					Number	Title	Pressure rating IN
		0.6	1.0	1.6	2.5	4.0			
HG20527-1992	Steel pipe flange	0.6	1.0	1.6	2.5	4.0	DIN2527-1992	Blind flanges	0.25~10.0
HG20592-1992		0.6	1.0	1.6	2.5	4.0	DIN2566-1975	Threaded flanges	1.0~1.6
HG20592-1997		0.6	1.0	1.6	2.5	4.0	DIN2573-1975	Plate slip-on welding	0.6~1.0
HGJ44~76-1991		0.6	1.0	1.6	2.5	4.0	DIN2655-1975	Flat welding	0.25~4.0
GB112-9123-2000		0.6	1.0	1.6	2.5	4.0	DIN2673-1962	Butt-welded loose flanges with welding ring	1.0

5.3 Magnetic Filter

A magnetic filter is recommended to be installed upstream of the flowmeter inlet if the medium contains ferromagnetic particles. The filter height is 100mm for the pipe diameter 100mm and below, and 150mm for DN 100 and above.

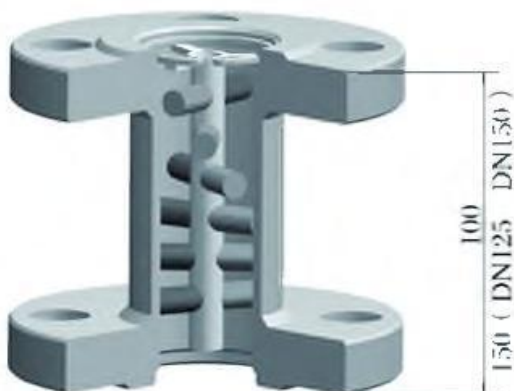

Fig.19

6 Indicators and Limit Alarm Devices

The indicator of the metal tube rotameter serves as the display and signal-conversion section of the flowmeter. The limit alarm switch is on when the flow exceeds the limit.

6.1 Indicator Selection

The local-display type, an electric remote-transmission type, or a HART-enabled type are available, among which users can select a suitable type based on the actual site requirements.

Detailed function descriptions of various indicators are shown in the table below.

Table 12

Indicator type	Function description
M1 type	The flow rate is indicated locally by a pointer. No power supply is required, and there is no 4~20mA remote transmission. A flow alarm device can be installed. The dial can be set to instantaneous flow rate or percentage value.
M3 type	Local digital display, battery powered, no 4~20mA remote transmission. LCD displays instantaneous and cumulative flow; on-site buttons allow viewing and modification of relevant parameters. The battery can last for 2 years. When the display shows the character "T", the battery should be replaced (battery model ER26500, 3.6V, 7.5AH, -20°C~60°C).

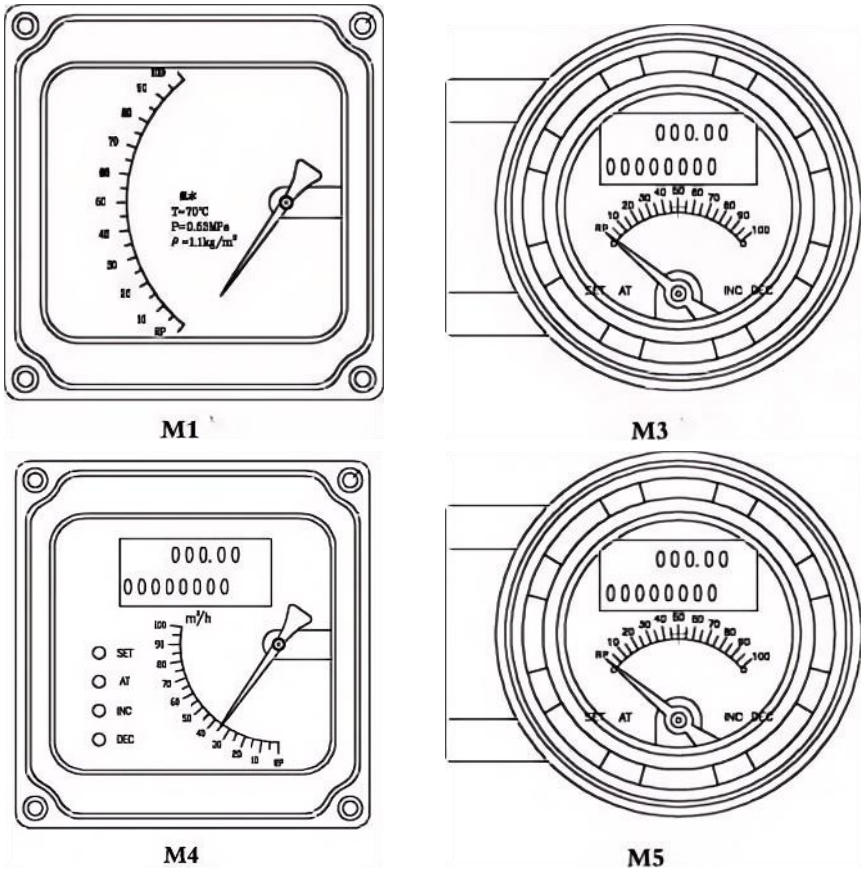

Fig.20 Indicator diagram

6.2 Alarm Device Selection

- (1) The K1 and K2 limit alarm switches are installed in the M1-type local indicator. K1 is the lower limit, and K2 is the upper limit; the alarm point can be set arbitrarily.
- (2) The K1 and K2 alarm switches consist of two parts: one part is inside the indicator, referred to as **TG22**. TG22 consists of an SJ3.5N sensor and a cutting disc on a rotating shaft. It allows the alarm point to be set anywhere within the entire flow range, with the setpoint indicated by a position pointer on the scale dial. The other part is the **external WE77/Ex transistor relay**. When used together with the SJ3.5-type sensor, the WE77/x-1 and WE77/Ex-2,

transistor relays enable remote transmission of upper- and lower-limit alarm signals.

- WE77/Ex-1 can be paired with one SJ3.5 sensor, providing control of a single alarm point.
- WE77/Ex-2 can be paired with two SJ3.5 sensors, providing control of both upper and lower alarm points.

6.2.1. Technical Parameters Of The WE77 Transistor Relay and SJ3.5 Sensor

Table 13

Model	WE77/E - 1	WE77/E - 2	Model	SJ 3.5 - N	SJ 3.5 - SN
Power supply	220VAC 24VAC		Power supply	8VDC	8VDC
Contact capacity	3A		Effective area ON	≥3mADC	
Power consumption	Approximately 3.5VA		Effective area OFF	≤1mADC	≤1mADC
Operating temperature	-25°C~ 60°C		Self-inductance	250μH	100μH
Open circuit voltage	8 (13.5) V	8 (13.5) V	Self-capacitance	50nF	60nF
Short current	8 (31) mA	8 (62) mA	Operating temperature	-25°C~70°C	-40°C~100°C
Allowable inductance	3 (31) mH	1 (7.6) mH			
Allowable capacitance	230 (609) nF	160 (539) nF			

6.2.2. Adjustment and Electrical Connection of the WE77 Transistor Relay and SJ3.5 Sensor

- (1) Transistor relays are composed of a power supply, a transistor rectifier amplifier, and an output intermediate relay.

(2) WE77EX-1 and WE77EX-2 are generally configured as normally open, but can be set as normally closed or normally closed with open-circuit monitoring by changing the wiring.

By replacing the jumper in the diagram below, various operating states can be obtained. An LED is used to represent "relay closed". (See Figure 21)

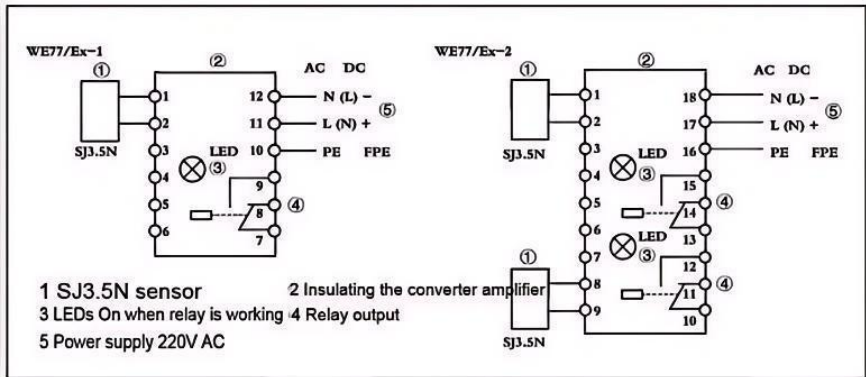

Fig.21

6.2.3. Installation and Dimensions of the WE77/Ex Transistor Relay

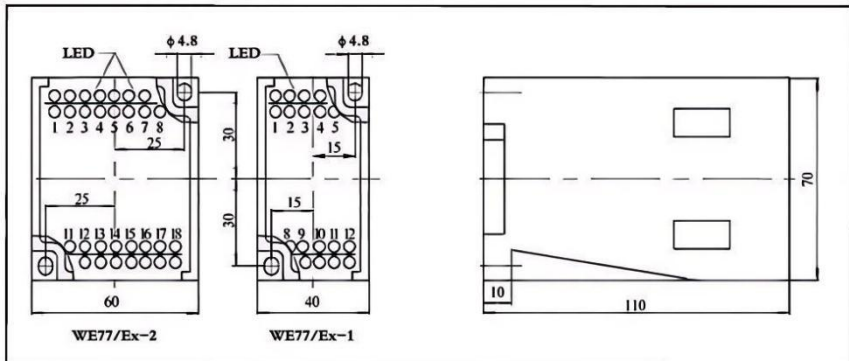

Fig.22

7 Diameter Calculation and Flow Rate

The flow rate measured and listed in the manual is based on the medium of water and air as the standard. Therefore, the flow rate of the actual medium must first be converted into the equivalent volumetric flow rate of water or air before selecting the corresponding meter size from the flow chart.

This chapter provides guidance on selecting the proper rotameter size during model selection.

7.1 Liquid Flow Calculation

7.1.1. Volumetric Flow Rate of the Measured Liquid (Q_t)

Based on the liquid's density and maximum flow rate, substitute the values into Equation (1) to calculate the equivalent water flow rate. Then, locate the corresponding meter size and float number in the flow chart. Next, take the water flow rate associated with the selected float number and substitute it back into Equation (1) to determine the actual liquid flow rate. After making the necessary adjustment to this value, the final calibrated flow range for the measured liquid can be determined.

$$Q_s = \sqrt{\frac{(\rho_f - \rho_s) \rho_t}{(\rho_f - \rho_t) \rho_s}} \times Q_t \quad \dots\dots\dots (1)$$

In the formula:

Q_t :	The maximum volumetric flow rate of the liquid being measured
Q_m :	The maximum mass flow rate of the liquid being measured
Q_s :	Calibration medium water flow rate
ρ_f :	Density of the float
ρ_t :	Density of the liquid being measured
ρ_s :	Density of calibration medium water

7.1.2. Mass Flow Rate of the Measured Liquid Q_m

The calculation method is the same as above, and the calculation formula is based

on formula (2).

$$Q_s = \sqrt{\frac{\rho_f - \rho_s}{(\rho_f - \rho_t) \rho_t \rho_s}} \times Q_t \quad \dots\dots\dots (2)$$

7.1.3. Calculation Examples

Example: For a certain liquid with an operating density of 720 kg/m³ and a maximum flow rate of 1800 l/h, calculate the meter diameter, float number, and scale range.

Solution: Take the density of the float as 7850 kg/m³ and the density of water as 1000 kg/m³, and substitute 720 (kg/m³) and 1800 (l/h) into formula (1).

$$\text{Get: } Q_s = \sqrt{\frac{(7850 - 1000) \times 720}{(7850 - 720) \times 1000}} \times 1800 = 1497.06$$

Refer to the flow chart, the meter size is determined as DN25, with a float number of F25.2 and a corresponding water flow rate Q_s = 1600. Substituting Q_s back into formula (1), it calculates Q_t = 1923.77. After rounding, the range of the liquid being measured can be determined to be 190~1900 L/h.

7.2 Calculation of Gas Flow Rate

Because gases are significantly affected by temperature and pressure, their flow calculation differs from that of liquids. When converting gas flow rates, both density and operating conditions, namely temperature and pressure, must be taken into account. Therefore, accurate information on the temperature and pressure of the gas under actual operating conditions is essential.

(1) If the user provides the gas volumetric flow rate under standard conditions, then calculate according to equation (3):

$$Q_s = \sqrt{\frac{\rho_{st}}{\rho_s} \times \frac{P_s}{P_t} \times \frac{T_t}{T_s}} \times Q_N \quad \dots\dots\dots (3)$$

(2) If the user provides the gas volumetric flow rate under operating

conditions, it shall be calculated according to equation (4):

$$Q_s = \sqrt{\frac{\rho_{st}}{\rho_s} \times \frac{P_s}{P_t} \times \frac{T_t}{T_s}} \times Q_t \quad \dots\dots\dots (4)$$

(3) If the user provides the gas mass flow rate, then calculate according to equation (5):

$$Q_s = \sqrt{\frac{1}{\rho_t \times \rho_s}} \times Q_m \quad \dots\dots\dots (5)$$

In the formula:

Q_N :	Maximum volumetric flow rate of gas under standard conditions	(Nm ³ /h)
Q_t :	Maximum volumetric flow rate of gas under operating conditions	(m ³ /h)
Q_m :	Maximum gas mass flow rate	(kg/h)
Q_s :	Volumetric flow rate of air under calibrated conditions	(m ³ /h)
ρ_{st} :	Density of gas under calibrated conditions	(kg/m ³)
ρ_s :	Density of air under calibrated conditions	(kg/m ³)
ρ_t :	Density of gas under operating conditions	(kg/m ³)
ρ_s :	Absolute pressure of air under calibrated conditions	(0.1 /MPa)
ρ_t :	Absolute pressure of gas under operating conditions	(MPa)
T_s :	Absolute temperature of air under calibrated conditions	(K)
T_t :	Absolute temperature of gas under operating conditions	(K)

(4) Calculation Examples

For a given gas, carbon dioxide with an average molecular weight of 44, under operating conditions of 0.2 MPa pressure and 25 °C process temperature, and a maximum flow rate of 48 Nm³/h, determine the required meter size, float number, and calibrated scale range.

Answer:

$$\rho_{st} = 1.803 \text{ kg/m}$$

$$P_t = 0.2 + 0.1 = 0.3 \text{ MPa}$$

$$\rho_s = 1.2041 \text{ kg/m}^3$$

$$T_t = 273.15 + 25 = 298.15 \text{ K}$$

$$P_s = 0.1 \text{ MPa}$$

$$T_s = 293.15 \text{ K}$$

Substitute the above known condition into formula (3).

$$\text{Get: } Q_s = \sqrt{\frac{1.803}{1.204} \times \frac{0.1}{0.3} \times \frac{298.15}{293.15}} \times 48 = 34.2$$

From the flow meter, we find: meter size DN25, float number F25.1. After adjustment, $Q_s=35$. Substituting Q_s back into formula (3), we get $Q_N=49.123 \text{ Nm}^3/\text{h}$. After rounding, the calibration range of the measured medium is: 4.9 ~ 49 Nm³/h.

7.3 Float Density Table for Various Materials

Table 14

Material	CrNi stainless steel	PTEE (Polytetrafluoroethylene)	C4 Hastelloy	Ti titanium alloy
Density(t/m ³)	7.85	3.4	8.3	5.1

Note: Standard conditions: 0 °C (273.15K), 0.1MPa

Calibration conditions: 20 °C (293 , 15K), 0.1MPa

7.4 Flow Tables

(1) Vertically installed rotameter (see Table 15)

Table 15

Diameter	Float	water L/h (0.1013MPa, 20 °C)		air m ³ /h (0.1013MPa, 20 °C)	Pressure loss kPa (Low pressure loss requirement to be negotiated with the manufacturer)	
		Stainless steel	PTFE, Ti	Stainless steel	Stainless steel	PTFE, Ti
DN 15	F15.0	1 0	-		1.5	-
	F15.1	1 6	-	0.5	1.5	-
	F15.2	2 5	-	0.7	1.5	-
	F15.3	4 0	25	1.2	1.5	1.5
	F15.4	60	40	1.8	1.5	1.5
	F15.5	100	60	2.8	1.5	1.5
	F15.6	160	100	4.5	1.5	1.5
	F15.7	250	160	7.5	3.0	1.5
	F15.8	400	250	1 2	3.0	3.0
	F15.9	600	400	1 8	3.5	3.0
DN 25	F25.0	1000	600	30	1.5	1.5
	F25.1	1200	800	35	1.5	1.5
	F25.2	1600	1000	45	3.0	1.5
	F25.3	2000	1200	60	3.0	1.5
	F25.4	2500	1600	75	3.5	3.0
	F25.5	3000	2000	90	3.5	3.0
	F25.6	4000	2500	120	8.0	3.5
	F25.7	5000	3000	150	8.0	3.5
	F25.8	6000	-	180	16.0	-
DN50	F50.0	6000	4000	180	3.0	3.0
	F50.1	8000	5000	240	3.0	3.0
	F50.2	10000	6000	300	4.0	3.0
	F50.3	12000	8000	360	4.0	3.0
	F50.4	16000	10000	480	8.0	4.0
	F50.5	20000	12000	600	8.0	4.0
DN80	F80.0	25000	16000	750	14.0	8.0

7 Diameter Calculation and Flow Rate

Diameter	Float	water L/h (0.1013MPa, 20 °C)		air m ³ /h (0.1013MPa, 20 °C)	Pressure loss kPa (Low pressure loss requirement to be negotiated with the manufacturer)	
	F80.1	30000	20000	900	14.0	9.0
	F80.2	40000	25000	1200	20.0	12.0
	F80.3	50000	30000	1500	20.0	15.0
DN100	F100.0	60000	40000	1800	2 8.0	25.0
	F100.1	80000	50000	2400	2 8.0	27.0
	F100.2	100000	60000	3000	4 0.0	38.0
DN125	F125.1	100000	80000	3000	4 5.0	35.0
	F125.2	125000	100000	-	4 8.0	40.0
DN150	F150.1	125000	100000	-	4 8.0	40.0
	F150.2	150000	125000	-	5 0.0	42.5

(2) Horizontally installed rotameter (see Table 16)

Table 16

Diameter	Float	water L/h (0.1013MPa, 20 °C)		air m ³ /h (0.1013MPa, 20 °C)	Pressure loss kPa (Low pressure loss requirement to be negotiated with the manufacturer)	
		Stainless steel	Ti		Stainless steel	Ti
DN15	F15.5	160	100	4.5	1.5	1.5
	F15.6	200	120	6.0	1.5	1.5
	F15.7	250	160	7.5	2.0	2.0
	F15.8	400	250	1 2	2.0	2.0
	F15.9	600	400	1 8	3.5	3.5
DN25	F25.0	1000	600	30	1.5	1.5
	F25.1	1600	1000	45	1.5	3.0
	F25.2	2000	1200	60	3.0	3.0
	F25.3	2500	1600	75	3.0	3.5
	F25.4	3000	2000	90	3.5	3.5
DN50	F25.5	4000	2,500	1 20	8.0	8.0
	F50.0	6000	4000	180	3.0	3.0
	F50.1	8000	5000	240	3.0	3.0

7 Diameter Calculation and Flow Rate

Diameter	Float	water L/h (0.1013MPa, 20 °C)		air m ³ /h (0.1013MPa, 20 °C)	Pressure loss kPa (Low pressure loss requirement to be negotiated with the manufacturer)	
	F50.2	10000	6000	300	4.0	4.0
	F50.3	12000	8000	360	4.0	4.0
	F50.4	16000	10000	480	8.0	8.0
DN80	F80.1	25000	16000	750	14.0	14.0
	F80.2	30000	20000	900	14.0	14.0
	F80.3	40000	25000	1200	20.0	22.0
DN100	F100.0	60000	40000	1800	30.0	30.0
	F100.1	80000	50000	2400	30.0	30.0
	F100.2	100000	60000	3000	45.0	45.0
DN125	F125.1	100000	80000	3,000	4 5.0	45.5
	F125.2	125000	100000	-	46.0	48.0
DN150	F150.1	125000	100000	-	4 8.0	46.0
	F150.2	150000	125000	-	5 0.0	50.0

Note: The data table is about the standard parameters of this rotameter. If users have special flow range requirements, please consult with the supplier.

8 Installation Method and Precautions

Different specifications of rotameters can be selected according to the on-site process piping layout. Among them, the vertical installation type is the standard type, while the other types are all extended types. Whenever on-site conditions permit, the vertical type should be given priority. The various installation types for the flowmeter can be referred to in the following diagram.

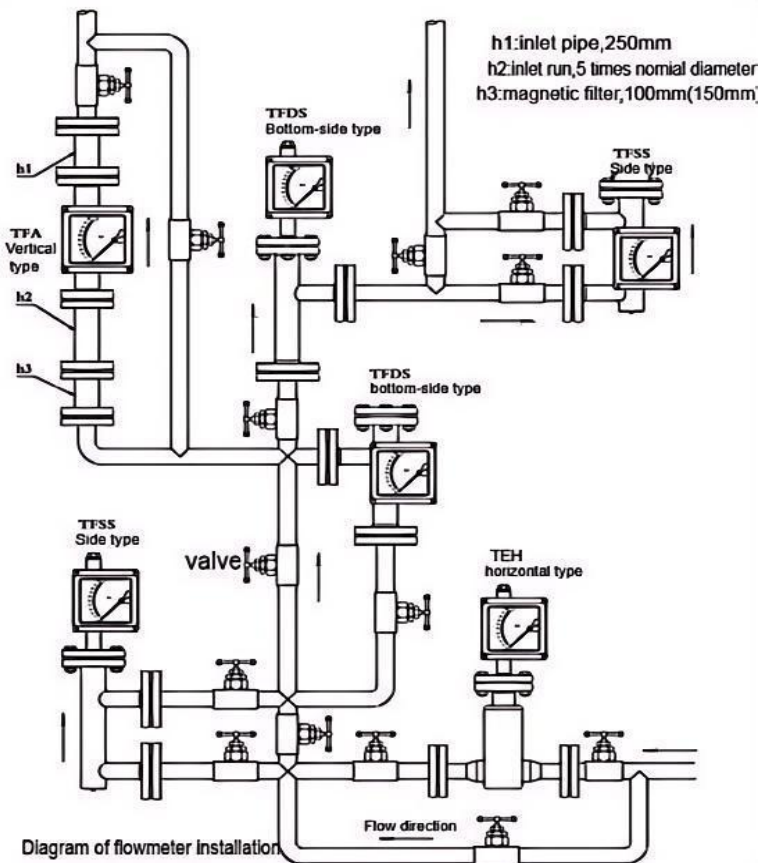

8.1 Installation Precautions

(1) Pre-installation Inspection:

Upon arrival at the site, unpack the instrument and remove all packaging materials. Carefully inspect the unit to ensure it has not been damaged during transportation.

(2) Pipeline Preparation:

Before installation, the process pipelines should be purged and cleaned to prevent ferromagnetic impurities from adhering to the instrument's float and affecting its normal measurement, which could seriously damage the instrument. If such contamination cannot be completely avoided, install a magnetic filter at the instrument inlet.

(3) Magnetic and Electromagnetic Interference:

The rotameter operates with magnetic coupling and a magnetic electric signal processor. To ensure proper operation, no ferromagnetic materials, strong magnetic fields, or significant electromagnetic fields should be present within 500 mm of the meter.

(4) Mechanical Stress Protection

The rotameter should not be subjected to mechanical loads from the process piping. Proper pipe supports must be installed at both the inlet and outlet to ensure minimal mechanical stress on the instrument body.

(5) Installation Orientation

Instrument installation is divided into horizontal installation and vertical installation. For vertically installed instruments, the verticality of the instrument should be ensured, and the tilt deviation should not exceed 3 degrees. For horizontally installed instruments, the horizontality of the instrument should be ensured, and the tilt deviation should not exceed 3 degrees.

(6) Upstream and Downstream Requirements

During installation, the diameter of the upstream and downstream pipes should be the same as the diameter of the rotameter. Flanges must be compatible and properly aligned. To ensure the measurement accuracy and stability, the upstream straight pipe length: $5 \times$ nominal diameter (5D); the downstream straight pipe length: ≥ 250 mm.

(7) Gas Measurement

If gas measured by the rotameter is discharged directly to the atmosphere, measurement instability or damage may occur. Under such conditions, a throttle valve should be installed at the instrument outlet.

(8) Installation of PTFE-Lined Instruments

Special care must be taken when installing instruments lined with PTFE. PTFE will be deformed under pressure or force. Do not overtighten bolts during installation. Refer to the following table for the recommended torque.

Table 17

Diameter (mm)	Maximum torque kgf.m	Double-ended bolt
DN15	0.9 ~ 0.95	4 x M12
DN25	2.0 ~ 2.2	4 x M12
DN50	5.2 ~ 5.6	4 x M16
DN80	4.5 ~ 4.8	8 x M16
DN100	4.6 ~ 5.0	8 x M16
DN125	5.0 ~ 5.3	8 x M18
DN150	6.5 ~ 6.8	8 x M20

8.2 Maintenance

- (1) The rotameter is a precision device and must be handled with great care during transportation, installation, storage, and operation. Avoid rough handling or improper placement. During all procedures, ensure that the sensor and indicator remain in their original relative positions; any shift may directly affect the measurement accuracy.
- (2) During long-term use, ferromagnetic impurities will inevitably adhere to the float inside the pipeline. This can cause the float to jam or affect the measurement accuracy. The float inside the sensor needs to be cleaned frequently. If a magnetic filter is installed inside, it also needs to be cleaned regularly.
- (3) The rotameter's indicator contains electronic components. After wiring or disassembling the housing, the screws must be tightened to ensure proper sealing. This prevents dust, moisture, or other contaminants from entering the meter and makes sure that the enclosure remains safely grounded.
- (4) When the rotameter is put into service for the first time, pay particular attention to valve operation. To prevent a sudden pressure surge from slamming the float into the stops and damaging the instrument, always open the valve slowly.
- (5) Rotameters for measuring gases are equipped with gas dampers to minimize float oscillations. To ensure float stability, a throttle valve can be installed at the instrument outlet. For remote-transmission models, power it on after verifying that all wiring is correct.

9 Electrical Connection

This section mainly introduces the flowmeter's power cable, its connection with the safety barrier, and the technical parameters of the safety barrier.

To begin, remove the front cover of the instrument:

- For square-case models powered by 24 VDC, a two-terminal power connection is located to the left of the LCD display.
- For battery-powered round-case models, a two-position DIP switch (battery switch) can be found at the lower-left side of the LCD.
- For round-case models powered by 24VDC or 220VAC, the power terminals are located to the left of the LCD, with a grounding connection required for isolation versions.

Wiring configurations based on power supply and output type are as follows:

- ❖ 24 VDC supply with 4-20mA output (or with HART): two-wire system
- ❖ 24 VDC supply with RS 485(Modbus) communication: three-wire system
- ❖ 24 VAC supply with RS-485(Modbus) communication: four-wire system

See the figure below for reference.

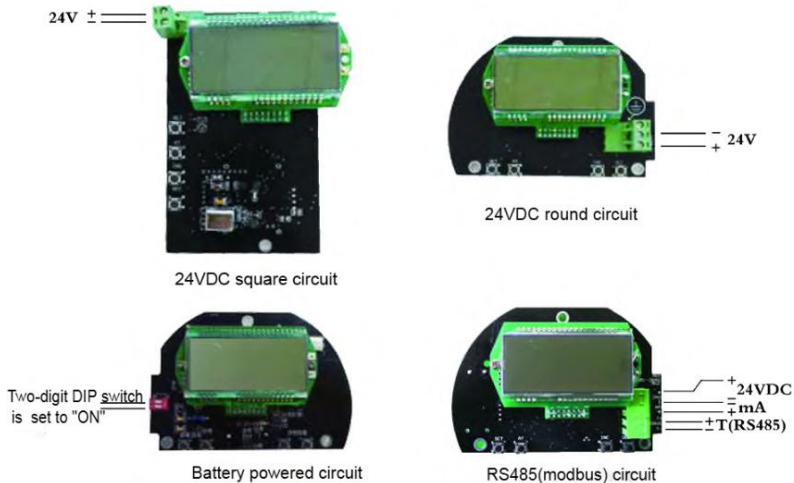

Note: After horizontally pulling the terminal block out of the circuit board, connect it to the power supply according to the positive and negative markings, then plug it back into the circuit board to complete the wiring.

Fig.23 Wiring diagram of the flowmeter and power supply

10 The Indicator Usage

The intelligent indicator directly displays the instantaneous and cumulative flow on the LCD screen. With the four buttons on the panel, users can also view the internal instrument parameters and reset certain settings to perform calibration.

This flowmeter provides access to three groups of instrument parameters. Users can view or modify a group by entering the corresponding password.

10.1 Button Functions

- **SET**: Confirms a parameter or function
- **AT**: Moves the cursor left
- **INC (+1)**: Moves to the next page or increases a value
- **DEC (-1)**: Moves to the previous page or decreases a value

10.2 Accessing Parameter Groups

In the measurement status, press the **SET** button until the display shows “CODE,” then release. Use the **AT** button to select the cursor position, and enter the required password with the **INC** and **DEC** buttons. Press **SET** to confirm and access the parameter group.

10.3 Modifying Parameters

- (1) Enter the first parameter group as described above.
- (2) Use the page buttons (**INC/DEC**) to scroll to the parameter you want to change.
- (3) Press **AT** to select the parameter for editing.
- (4) Move the cursor within the value using **AT**, and adjust the number using **INC** (increase) or **DEC** (decrease).
- (5) Press **SET** to confirm and save the changes.

10.4 The Parameter Groups And Their Passwords

(1) Group 1: Basic parameters, see the table below for details, password (CODE): 000001

Parameter	Meaning	Set range	Description
dpl	Decimal point setting value	0 ~ 3	corresponding number of bits
IEL	Cumulative flow high 6-digit value	Automatically record the high-order digits of the totalized flow	For read-only digits
dFL	4mA calibration value	After entering this parameter, measure the current value with a high-precision ammeter, then input the multimeter current reading into this parameter for confirmation, and the 4mA output will be automatically calibrated.	
dFH	20mA calibration value	Same calibration method as dFL, but for the 20mA output	
Cod	Slope correction value	Default 1.0	
SPH	Full-scale setting value		
dLL	Small signal cutoff value	10% of full scale.	
LPd	The damping value can be set according to the on-site conditions.	0-10	It is generally set to 4.
HFP	Final assembly code	Not set this parameter when HART communication is not required and this is a non-remote high/low alarm model	HART parameters
HFL	Sensor serial number	Do not set this parameter when	HART

Parameter	Meaning	Set range	Description
		HART communication is not required and this is a non-remote high/low alarm model	parameters
HFd	Flow unit	Loop display: m ³ /h, L/h, Nm ³ /h, NI/h, m ³ /min, 1/min, Nm ³ /min, NI/min, kg/h, t/h, kg/min, t/min	0-11
HdL	Flowmeter installation type	"0" represents bottom in, top out; "1" represents top in, bottom out.	The default value is 0.
HdC	HART communication address (0 ~ 15)	Not set this item if there is no HART requirement.	HART parameters
HdP	Device serial number	Not set this item if there is no HART requirement.	HART parameters
HCH	Current resolution	Internal parameters; no user settings required.	
SOP	ESC Interface		

Additional notes on basic parameters: When the flowmeter has a remote high/low-limit alarm function, the meanings of parameters HFP, HFL, and HFD change accordingly. In this case, the functions of the parameters are as follows:

Table 18 Remote alarm type parameters(Round-case transmitter version)

Parameter	Meaning	Set range	Description
HFP	Upper limit alarm	0-Full Scale	User-configurable. When the instantaneous flow exceeds this value, the upper-limit contact switch is activated (Alarm ON).
HFL	Lower limit alarm	0-Full Scale	User-configurable. When the instantaneous flow falls below this value, the lower-limit contact switch is activated (Alarm ON).

Parameter	Meaning	Set range	Description
HFD	Alarm point hysteresis setting	0 - 255	When the flow meter does not have a decimal setting
		0 - 25.5	When the flow meter is set to 1 decimal place
		0 - 2.55	The flowmeter is set to 2 decimal places
		0 - 0.255	When the flowmeter is set to 3 decimal places
<p>Note: When setting alarm values, the upper limit alarm value should be greater than the lower limit alarm value!</p> <p>Contact switch capacity: 250VAC 3A, passive switch output.</p>			

(2) Group 2: Manually clear the accumulated value, password (LOC): 000002

Entering this parameter group will clear the accumulated amount to zero, and then automatically return to the measurement state.

(3) Group 3: Restore factory settings, Password (LOC): 000009

Entering this parameter group can restore the flow meter's internal parameters to their factory settings.

10.5 Example: 4mA Current Correction

To enter the 4mA current correction, simply write the measured current value directly into the parameters to complete the correction.

11 Technical Specification

F.No										
Tag.No										
MFG.No										
Quantiy										
Nominal Diameter		DN PN		DN	PN		DN	PN		
Flange Standard										
Body Materials										
Float Materials										
Lining Materials										
Jacket data	Conn.Standard	DN PN		DN	PN		DN	PN		
	Heating Medium									
	Temp.C/Pres.Mpa	°C MPa		°C MPa		°C MPa		°C MPa		
Overall height										
Accuracy			%		%			%		
Flow Name										
Fluid Conditions		liquid <input type="checkbox"/> gas <input type="checkbox"/>		liquid <input type="checkbox"/> gas <input type="checkbox"/>		liquid <input type="checkbox"/> gas <input type="checkbox"/>		liquid <input type="checkbox"/> gas <input type="checkbox"/>		
Operating Conditions		Min	Nor	Max	Min	Nor	Max	Min	Nor	Max
Flow Rate /h										
Temperature °C										
Presure MPa										
Density kg/m³										
SPGR kgf/m³										
Viscosity mpa.s(cp)										
G.mol.Wt										
Project Range	Operating Dial		%		%		%		%	
	Standard Dial		%		%		%		%	
	Float No.									

MFG Range	Operating Dial	%		%		%	
	Standard Dial	%		%		%	
	Float No.						
Electrical Siganl Output		mA		mA		mA	
Power Supply		VDC V	Hz	VDC V	Hz	VDC V	Hz
Cable Conn.		M	× mm	M	× mm	M	× mm
Limit Switch		Max	Min	Max	Min	Max	Min

Name	TAG No.	Standard / Model	Quantity
Flanges			
Conn.Bolts			
Pressurize Mat			
Filter			
Other			

Accessories: Fittings

Note: Please contact our company for the technical data sheet for the metal tube rotameter!